



# Model 4023

## 3-Way Pressure Sensing Valve



### FEATURES

- SETTINGS TO 7600 PSI
- 2 OR 3-WAY ACTION
- BALANCED 3-WAY VALVE  
– PRESSURE CAN BE APPLIED TO ANY PORT
- 3-WAY VALVE SUITABLE FOR LP GASES, NATURAL GAS, OIL, AIR, ETC.
- BUBBLE-TIGHT SEALS WITH CENTER DEAD SPOT (NO PORT OVERLAP)
- FIELD ADJUSTABLE – RISING OR FALLING
- GULFPROOFED FINISH STANDARD
- ADJUSTABLE SETPOINT

### APPLICATIONS

- WELL HEAD CONTROL
- ACTUATOR PILOTING VALVE ACTUATOR
- SUCTION/ DISCHARGE PRESSURE

AMOT Model 4023 3-Way Pressure Sensing Valve can be used as a 2 or 3-way capacity, pressure sensing valve. This valve is ideal for applications that require compressor suction and discharge pressure sensing at high pressure levels. Dual purpose construction provides a wide latitude of applications and permits easy field adjustment or changeover from trip on falling to trip on rising pressure by changing the port piping and re-adjusting the setting. Trip settings are adjustable in eight ranges from 18 psi falling to 7600 psi rising pressure. The 4023 valve is suitable for use on air, hydraulic, or gas control systems with control system pressure up to 125 psi.

The 3-way valve has a pressure-actuated, spring-return operator. Without pressure applied to the sensed pressure port, Port 3 is open to Port 2. With pressure applied to the sensed pressure port, Port 3 closes before Port 1 opens to Port 2. A small dead spot on the center of the stroke prevents valve port overlap. The valve is normally set at the factory so that Port 1 just opens to Port 2 on a pressure rise to the specified tripping pressure setting. The valve is converted to 2-way action by plugging Port 1 or Port 3.

A manual reset feature is available to reset the valve after tripping. Pull out the reset knob to reset after trip on falling pressure. Push in the reset knob to reset after trip on rising pressure.

Units with Pressure Range Code Numbers 1 and 2 use a diaphragm with a gulfproofed aluminum housing to sense pressure. Units with a higher Pressure Range use a Teflon Lip-Type Seal on a stainless steel piston inside a stainless steel cylinder to sense pressure.

## HOW TO ORDER

When ordering please specify the following:

1. AMOT Model 4023.
2. Pressure Range Code No. from Table A.
3. Tripping Pressure.
4. Tripping Action:
  - a. To trip on rising pressure.
  - b. To trip on falling pressure.
5. Any of the following special features if required:
  - a. Viton Seals (instead of Buna N Ranges 1 & 2).
  - b. Manual Reset (instead of automatic).
  - c. BSP Parallel Port Thread (instead of NPT). Available from UK factory only.

This unit may be ordered using the full description as shown above or by constructing a Model No. using the Model Code System. The complete Model No. for a standard unit with NPT threads, viton seals and automatic reset, set for a tripping pressure of 300 psi rising on Pressure Range No. 3 is 4023E340D set at 300 psi rising.

## INSTALLATION

Model 4023 can be mounted in any position. Use two 1/4" diameter screws through the holes in the back of the case, or two 3/8-16 screws into the case through a mounting plate on the back side. When manual reset (trip on falling pressure) is included, the valve should be mounted with the reset knob down. With manual reset (trip on rising pressure), the valve should be mounted with the reset knob up. Frictional force of the seal rings holds Valve Spool (20) in position. Machine vibration can cause the valve to reset if not mounted as instructed.

If a 4023 Valve with Pressure Code Range Numbers 3 or higher have been in stock without being used for a long period of time, the Teflon Seal may leak slightly. It is recommended that this Seal be exercised by running the sensed pressure up and down its complete range about six times to overcome any leakage problems.

Control pressure, sensed pressure sources and inter-connecting tubing must be free of dirt, chips, rust and other contaminants. Apply a quality thread sealant such as Loctite™ Pipe Sealant to pipe thread connections. Avoid applying excessive torque on fittings at Ports 1, 2, and 3.

## ADJUSTMENT

If adjustment is necessary, turn Adjusting Nut (11) clockwise to raise the setting or counter-clockwise to lower it. See cross section drawing on the next page.

## MODEL CODE SYSTEM

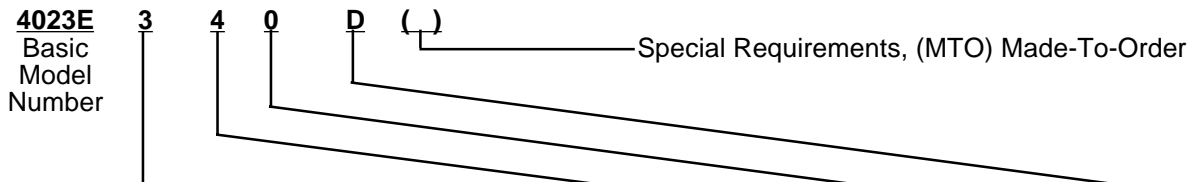

TABLE A PRESSURE RANGE CODE NO.					TABLE B PORT THREADS & FINISH CODE NO.			TABLE C RESET TYPE CODE NO.		TABLE D SEAL MATERIAL CODE NO.		
Code No.	Rising (psi)	Falling (psi)	Differential Pressure (psi)	Proof (psi)	Code No.	Threads	Finish	Code No.	Reset	Code No.	Material	For Pressure Range No.
1	20 - 50	18 - 50	4 - 7	350	2	BSP(PL)*	Standard	0	Automatic	A	Buna N	1 & 2
2	30 - 125	25 - 115	7 - 12	350	3	BSP(PL)*	Gulfproof	1	Manual	C	Viton	1 & 2
3	130 - 400	100 - 370	35 - 50	1500	4	NPT	Gulfproof (Standard)	3†	Pneumatic (Special Order)	D	Viton	3 through 8
4	250 - 800	200 - 700	46 - 60	1500								
5	400 - 1100	275 - 900	100 - 145	3500								
6	650 - 2250	500 - 2000	120 - 170	3500								
7	1000 - 3500	750 - 3000	300 - 400	10,000								
8	1450 - 7600	1000 - 7000	400 - 600	10,000								

\* Available from U.K. factory only.

\*\* The differential pressures shown are based on 3-way operation of the valve piloting opposed 2400D Indicating Relays at Port 1 and Port 3, and operating at a level of 50 psi air pressure in the valve. For 2-way valve operation controlling a 2400D Relay, the differential will be slightly less than shown.

**NOTE:** Letters or numbers in the MTO space, other than nothing, AI or AA, indicate the unit is built to special requirements and some of the other code numbers may not be valid. Check with the factory for full specification of such models.

† Only available on rising pressure

☐ = Non Standard Product, special charges may apply.

# SPECIFICATIONS

Maximum Operating Pressure	
at Ports 1, 2, and 3 .....	125 psi (860 kPa)
Maximum Temperature .....	150°F (66°C)
Valve Free Flow Area	
Equivalent to 9/32 Diameter Port .....	Cv = 1.2
Housings .....	Anodized Aluminum
Piston and Cylinder .....	Stainless Steel
3-Way Valve Spool .....	Glass Reinforced Ryton
Standard Seals and Diaphragm .....	Buna N
Piston Seal .....	Teflon
Net Weight .....	4 lbs. (1.81 Kg)
Shipping Weight .....	5 lbs. (2.26 Kg)

This valve makes use of AMOT's patented "Tadpole" Seal which provides for lower friction and longer cycle life than conventional O-rings (U.S. Pat. No. 3,926,444).

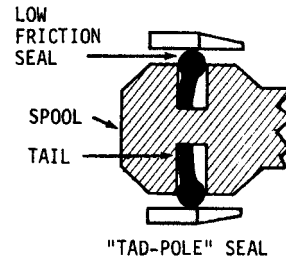

# DIMENSIONS

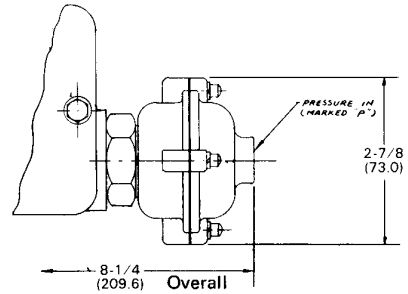
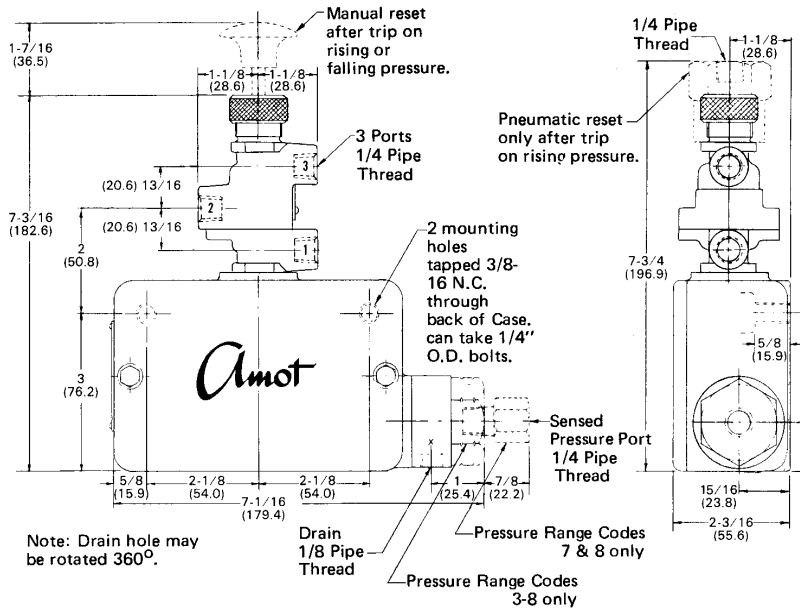

Dimensions with Diaphragm Operator. Pressure Range Codes 1 & 2

# CUTAWAY

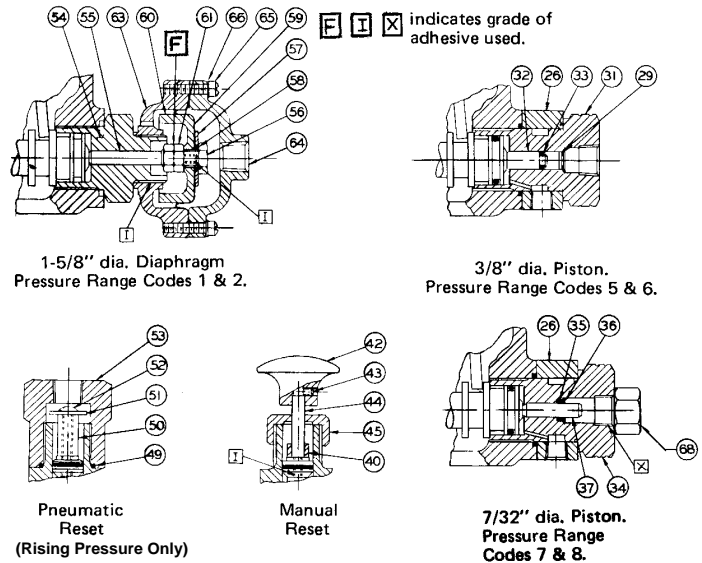
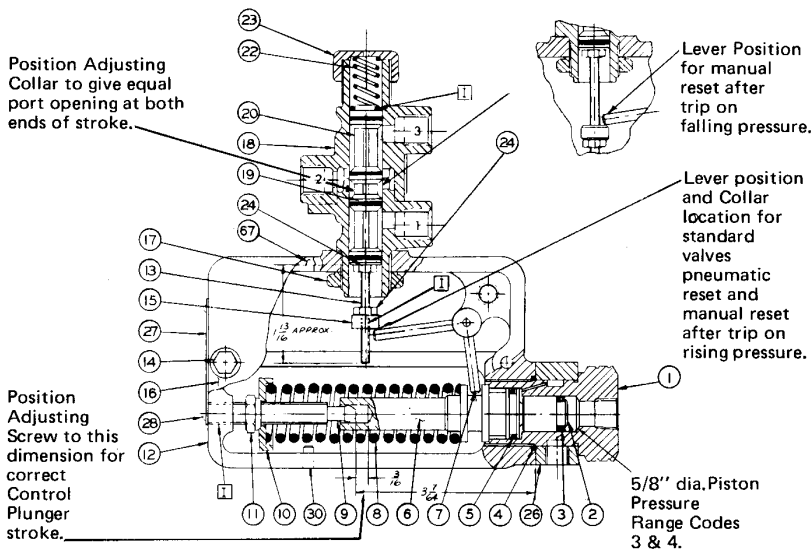

When communicating with AMOT regarding operation of a control, always give the model number and the Serial No. If ordering Service Parts, also include the Description, Part No. and quantity desired. If any parts are ordered by Reference No. only, please also include the Form No. and Revision No. and date of this brochure.

# MAINTENANCE

Properly applied and installed 4023 valves require minimal maintenance. Unless leakage or other problems are noticed earlier, an inspection of the units at yearly intervals is adequate to detect and make provision for normal wear and preventive maintenance. Lubrication of Seal Rings (19) in addition to other O-rings and seals may be the only maintenance required. To remove Spool (20) with seal rings from the 3-way valve, first unscrew Cap (23). Remove the spool carefully from the valve to avoid damaging the bore. Clean the valve and spool. Wash out the old grease and inspect the seals for wear, damage, or hardness. If only lubrication is required, apply a coating of Dow-Corning No. 33 (AMOT No. 911L001) Grease. If tadpole seal ring (19) replacement is necessary, clean out the spool grooves and fill them with grease. Install the seal rings by first inserting the thin tail section of seal ring into one side of the groove. Work around the ring until it is uniformly positioned. Remove excess grease and re-install the spool. Exercise the same care in cleaning, lubricating and/or replacing the piston seals, diaphragm and O-rings.

When installing Teflon Seals, (3, 33, 35) place the lip toward the pressure side so that pressure will expand the lip toward the bore. After installing Teflon seals, they should be exercised in the bore to prevent leakage

by running the sensed pressure up and down the complete range about 6 times. This exercise operation can be performed on the machine while it is running. It is recommended that Model 4023 be checked monthly for proper functioning by simulating an unsafe condition.

AMOT designs and tests all products to ensure that high quality standards are met. This product should last for many years. For good product life, carefully follow AMOT's installation and maintenance instructions; failure to do so could result in damage to the equipment being protected.

## SERVICE KITS

Service Kit 9132X				
Model 4023E1--A 4023E2--A				
Ref No.	Qty.	Description	Part No.	
19	4	Seal Ring, Buna N	7896L001	
58	1	O-ring, Buna N	143	
59	1	Diaphragm, Buna N	2254	
67	1	Gasket	7544	

Service Kit 9132X001				
Model 4023E1--C 4023E2--C				
Ref No.	Qty.	Description	Part No.	
19	4	Seal Ring, Viton	7896L002	
58	1	O-ring, Viton	143L001	
59	1	Diaphragm, Viton	2254L002	
67	1	Gasket	7544	

Service Kit 9155X001				
Model 4023E3--D 4023E4--D				
Ref No.	Qty.	Description	Part No.	
3	1	Seal, Teflon	831L014	
4	1	O-ring, Buna N	743	
5	1	O-ring, Viton	142L001	
19	4	Seal Ring, Viton	7896L002	
67	1	Gasket	7544	

Service Kit 9155X003				
Model 4023E5--D 4023E6--D				
Ref No.	Qty.	Description	Part No.	
4	1	O-ring, Buna N	743	
5	1	O-ring, Viton	142L001	
19	4	Seal Ring, Viton	7896L002	
33	1	Seal, Teflon	831L010	
67	1	Gasket	7544	

This Parts List is effective with Valve Serial No. C771.

### AMOT USA

8824 Fallbrook Dr  
Houston, TX 77064  
Tel: +1 281 940-1800  
Fax: +1 281 668-8802

### AMOT

Western Way  
Bury St. Edmunds IP33 3SZ  
Suffolk England  
Tel: +44 1284 762222  
Fax: +44 1284 760256

### AMOT SINGAPORE

10 Eunos Road 8 # 12-06  
Singapore Post Centre  
Singapore 408600  
Tel: +65 6293 4320  
Fax: +65 6293 3307