



Model 4057/4457

3-Way Valves



FEATURES

- **BALANCED FORCE DESIGN-
PRESSURE CAN BE APPLIED
TO ANY PORT**
- **CENTER DEAD SPOT-STD.**
- **PORT OVERLAP-OPTIONAL**
- **ARRANGED FOR PANEL OR
BRACKET MOUNTING**
- **AVAILABLE IN ALUMINUM OR
316 STAINLESS STEEL**

APPLICATIONS

- **HYDRAULIC FLUID CONTROL**
- **ACTUATOR CONTROL**
- **PNEUMATIC PANEL SYSTEMS**
- **SAFETY CONTROL SYSTEMS**

AMOT Model 4057 or 4457 Valves were developed for use in manual and automatic hydraulic or pneumatic control systems. They offer versatility in operating requirements and allowable pressure limits. For a 1/4" size control valve, they offer exceptional flow capacity.

These valves are suitable for use on clean air, natural gas, L.P. gases, petroleum-base lubricants and hydraulic oils as well as many other fluids.

Each valve is carefully assembled, tested, and inspected to ensure that high quality standards are met. Valves are made from precision cast and machined aluminum or stainless steel parts. The unique porting arrangement eliminates seal ring cutting, and permits pressure inlet at any port without danger of seal "blow out". Standard construction permits valve pressures to 125 psi.

Certain of these valves are completely unique in the industry. For example, the 4057 or 4457 Type CP has a manual reset latch which automatically will drop out on introduction of pilot pressure, and permits return stroke on loss of pilot pressure.

These valves make use of AMOT's patented "Tad-Pole" seal which provides for lower friction and longer cycle life than conventional O-rings. (U.S. Pat. No. 3,926, 444).

INSTALLATION

All connections on 4057 and 4457 Valves are made with 1/4" pipe thread fittings. Apply a quality thread sealant such as Loctite Pipe Sealant to pipe thread connections but do not permit it to enter the valve passages. Teflon thread sealing tape may be used but must be applied so that shreds of the tape do not enter the valve.

Avoid overtightening fittings on the valve port bosses as they may be cracked, especially when Teflon thread sealing tape is used.

All valves may be bracket mounted; most are also suitable for panel mounting. A Satin Chrome Nut, Part No. 3496L001, is available as an option for most types. It substitutes for standard Nut (8) to improve the appearance for front of panel mountings. A red Knob, Part No. 681L001, is available for Types CA, CB, CD or CE if desired as a substitute for standard black Knob (11).

DIMENSIONS

Dimensions in Inches
Millimeters in ()

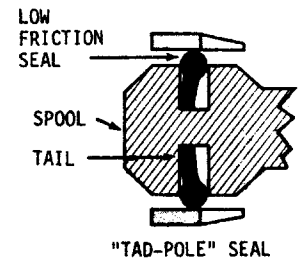
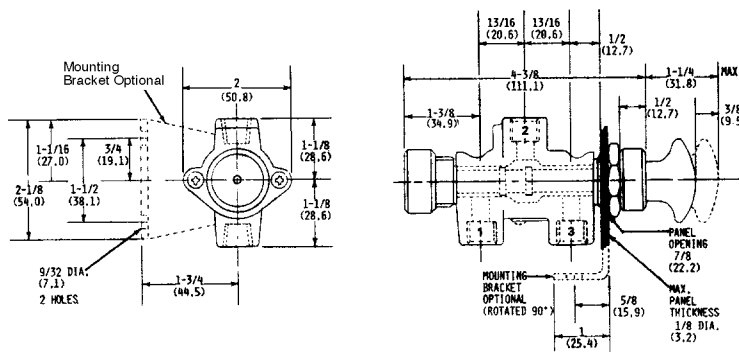

OPERATION

AMOT Model 4057 and 4457 3-Way Valves feature modular construction and incorporate a sliding spool. The standard spool has a small center dead spot position and no valve port overlap. With the spool fully to the left (rest position) as shown in the diagrams, Port 2 is open to Port 3 and Port 1 is closed. With the spool moved to the right (actuated

position), Port 2 is open to Port 1 and Port 3 is closed. The valves are available with a variety of manual and pressure operators and with manual, pressure or spring returns. See the Valve Type Description Table for the standard variations which are available.

MODEL CODE SYSTEM

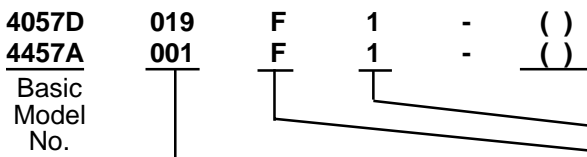

Note: Letters or numbers in the MTO space, other than nothing, A1 or AA, indicate the unit is built to special requirements and some of the other code numbers may not be valid. Check with the factory for full specification of such models.

Valve Type	Table A Operator, Finish & thread Code No.				Table B Seal Material Code No.	Table C Spool Code No.	
	Stainless Steel NPT	Gulf-Proofed NPT	Stainless Steel *BSP (PL)	Gulf-Proofed *BSP (PL)		Standard	Valve Port Overlap
CA	001	019	073	091	F	1	2
CB	002	020	074	092	F	1	2
CD	004	022	076	094	H	1	2
CE	005	023	077	095	H	1	2
CP	007	025	079	097	H	1	2
SB	--	027	--	099	K	5	6
CT	--	029	--	101	K	1	2
CG	013	031	085	103	H	1	2
CF	014	032	086	104	J	1	2
CZ	--	035	--	--	J	1	2

* Available from U.K. Factory Only

-- Not Available

SPECIFICATIONS

Body Material 4057; precision cast aluminum
4457; stainless steel
Standard Spool Material glass reinforced Ryton
Standard Seal Material Viton
Maximum Temperature 250°F (120°C)
Flow Coefficient (equivalent to 9/32 dia. port) C = 1.2
Maximum Pressure at Ports 1, 2 or 3 *125 psi (860 kPa)
Maximum Pressure at Ports A or B 150 psi (1034 kPa)
Maximum Pressure at Port C (Types CT & SB)
**125 psi (860 kPa)
Net Weight 4057; 0.6 to 2.0 lbs (0.3 to 0.9 kg)
4457; 1.7 to 5.7 lbs (0.8 to 2.6 kg)

* 150 psi (1034 kPa) if a slight increase in operating force and pressure acceptable.

** 350 psi (2411 kPa) if a suitable orifice is used to prevent damage to valve components from sudden application of pressure.

VALVE TYPE DESCRIPTION TABLE

TYPE CA

Manual Operated
5 lbs Force Required

TYPE CF

Double Pilot Operated
10 psi Pressure Required

TYPE CB

Manual Pull
Spring Return
15 lbs Force Required

TYPE CG

Pressure Operated,
Spring Return
26 psi Pressure Required

TYPE CD

Manual or
Pressure Operated
Manual Return
10 psi Pressure or
6 lbs Force Required

TYPE C1

Normally Open
Pressure Operated
Internal Pressure Return

TYPE CE

Manual or
Pressure Operated
Spring Return
26 psi Pressure or
16 lbs Force Required

TYPE C2

Double Pilot Operated
Spring Return in One
Direction, 10 psi
and 26 psi required

Note: The symbol  does not designate a detent, but indicates that the valve has a memory and that the piston will remain in position until moved.

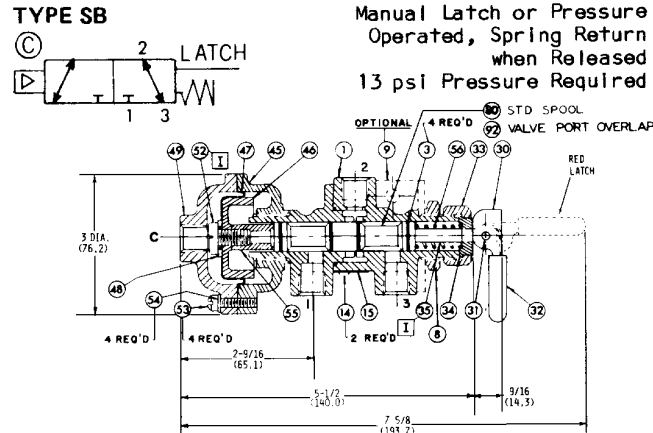
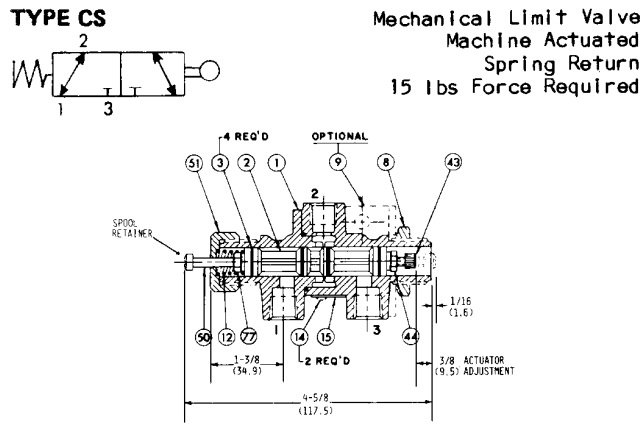
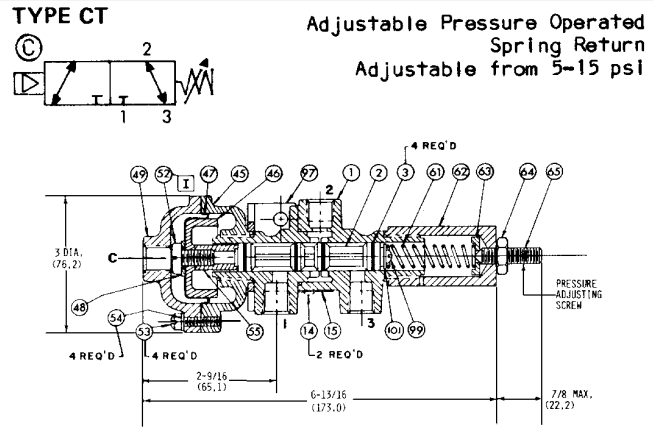
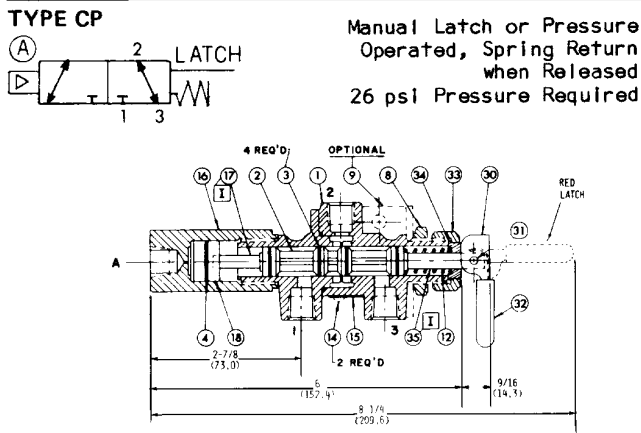

MAINTENANCE

AMOT 4057 and 4457 Valves make use of AMOT's "Tad Pole" rubber seals to provide low operating forces and high cycle life. Wear can be observed by checking for leakage which will increase as there is more wear.

To check the seal rings, the valve spool can be removed. This is done on most versions by simply removing the end cap and pulling out the spool. Spools on panel mounted valves can be removed from in front of the panel without disconnecting any piping.

To replace seal rings, remove the spool, take off the old rings, thoroughly clean the grooves, and coat the grooves with Dow Corning No. 33 grease (AMOT Part No. 911L001). Lightly coat the new rings with grease and install them, first inserting the thin tail section of the ring into one side of the groove. Work around the ring until it is uniformly positioned. Remove excess grease and reinstall the piston.

When these valves are used in safety control systems, it is recommended that the system be checked monthly for proper functioning.

When communicating with AMOT regarding operation of a control, always give the Model No. and Serial No. If ordering service parts, also include the Description, Part No., and quantity desired. If any parts are ordered by Reference No. only, please include the Form No., Revision No., and date of the brochure.

SERVICE KITS

Ref No.	Part No.	Qty	Description
For all Types except CT & SB (Viton) Kit 9113X001			
3	7896L002	4	Seal Ring, Viton
4	7898L002	2	Seal Ring, Viton

Service Kit 9113X002 may contain extra parts when used with some valve types.

For Types CT & SB (Viton)			Kit 9128X001
3	7896L002	4	Seal Ring, Viton
47	2254L002	1	Diaphragm, Viton
48	7898L002	1	Thread Seal

SERVICE PARTS

Ref No.	Part No.	Qty	Description
3	7986L002		Seal Ring, Viton
4	7898L002		Seal Ring, Viton
47	2254L002		Diaphragm, Viton,
			for Types CT & SB
48	714L004		Seal Ring, Viton

These Parts Lists effective with Valve Serial No. C761.

AMOT USA
401 First Street
Richmond, CA 94801
Tel: +1 510 236-8300
Fax: +1 510 234-9950

AMOT
Western Way
Bury St. Edmunds IP33 3SZ
Suffolk England
Tel: +44 1284 762222
Fax: +44 1284 760256

AMOT SINGAPORE
10 Eunos Road 8 # 12-06
Singapore Post Centre
Singapore 408600
Tel: +65 6293 4320
Fax: +65 6293 3307