



# Model 4103 D

## Temperature Valves

Patented



**4103D  
Temperature Valve**

**6710X Replaceable  
Fuse Rod Assembly**

## FEATURES

Protects stationary bearings and other parts from damage due to unsafe high temperature levels.

- RELIABLE PROTECTION
- INSTANT RESPONSE
- COMPACT DESIGN
- EASE OF INSTALLATION
- USE WITH OIL, AIR, OR GAS
- SIZES TO FIT MOST ENGINES

## APPLICATIONS

- HIGH BEARING AND FLUID TEMPERATURE DETECTION
- POWER OR COMPRESSOR CYLINDER OVERLOAD
- HIGH PACKING GLAND TEMPERATURE DETECTION
- HIGH DISCHARGE TEMPERATURE DETECTION

AMOT Model 4103 Temperature Valves provide a low cost, reliable sensor which will initiate a warning or shutdown upon a sudden temperature rise in critical machine parts. Such temperatures may arise from tight, worn or out-of-round bearings, tight packing glands, cracked or broken shafts, torsional vibration, power or compressor cylinder overload, lack of lubricant flow and many other sources. Model 4103 Valves may be used in medium to large stationary bearings and can be applied to liquid systems by installing them in a 6721L Well. For similar capabilities in moving bearing applications, refer to AMOT's Model 4102 Temperature Detectors.

Model 4103 has a stainless steel body containing a normally closed valve sealed with a Viton ball. The temperature sensing portion of the 4103 is a thin film of eutectic alloy located near the tip of the Fuse Rod Assembly. This eutectic alloy, less than 0.001 cubic inch in volume, secures a spring loaded fuse rod until the temperature at the sensing end of the rod melts the alloy. The fuse rod is then instantly released and allows the spring-loaded rod to unseat the Viton valve ball. A stainless steel ball is an optional item for use with lube oil as the control medium if high pressures are to be encountered. Generally, the standard Viton ball is recommended for use with air, gas, or lube oil control systems because it provides a leak-tight seal.

## INSTALLATION

AMOT Model 4103 Temperature Valves are the basic sensing units in a safety system and must be tied into the system through connecting tubing. Control pressure may be clean, dry air, or a non-corrosive liquid such as lubricating oil at up to 90 psi.

**FORM 655**

Air systems are more versatile and will give faster response than an oil pressured system. Oil is used in many systems on an engine as shown in Figure 5. Connecting tubing should be 5/16" O.D. Close-tee each sensing device to the control pressure line and pipe them in series with the pressure sensing valve being the last component in the line. Care should be taken not to over tighten the fitting in the Vent port since it may interfere with the tripping action.

AMOT Model 4103DD Temperature Valves are used where standard metal thicknesses are held by machined surfaces. The Locknut (6) and Spacer (11) arrangement permits installing the valve without the use of a gauge in standard depths of 1-1/16" to 1-9/16" as follows:

**Installed Depths**

Nut plus 3 Spacers	1-1/16
Nut plus 2 Spacers	1-3/16
Nut plus 1 Spacer	1-5/16
Nut only	1-7/16
No Nut or Spacers	1-9/16

Removal of one Shim (12) changes the direction of the vent port approximately 90° when the valve is tightened. The Shims may be removed as necessary to obtain the required vent location.

AMOT Model 4103D Valves can be installed by themselves (Figures 1 & 2), in Adapters (Figure 3) or in a Well (Figure 4). Care must be used to obtain the proper relationship between the pin on the Fuse Rod Assembly and the Valve Ball. Table B minimum dimensions on the outline drawing is

available in 1/2" increments from 1-7/8" to 9-7/8" and must be held to within +/-1/16" when the unit is installed. To accomplish this setting, use one or both of the following methods.

**Air Pressure** – Install the Valve in the mounting hole and apply slight air pressure to the IN Port of the valve. Turn the Valve into the hole until the Valve starts to leak at the Vent Port, then back off one turn and tighten in place with Locknut (6).

**Gauge** – Install the Valve in the mounting hole and thread it in until the Gauge (AMOT Part No. 6722) strikes the 3/16" diameter Fuse Rod when inserted in the Vent Port. Turn the Valve back out until the gauge slides past the 3/16" rod and seats fully, with the small pin located in the gauge slot as shown in Figure 2. Remove the Gauge and thread the Valve in one or two turns and tighten in place with Locknut (6).

**ADAPTER** See Fig. 3

Part No.	Length	"L"
6660L001	4-3/8	(111.1)
6660L002	2-1/2	(63.5)
6660L003	1-1/4	(31.8)
6660L004	6	(152.4)
6660L005	5	(127.0)
6660L006	2-7/8	(70.4)
6660L007	4-5/8	(113.3)
6660L008	1-1/2	(38.1)

**DIMENSIONS/INSTALLATIONS**

Dimensions in Inches  
Millimetres in ( )

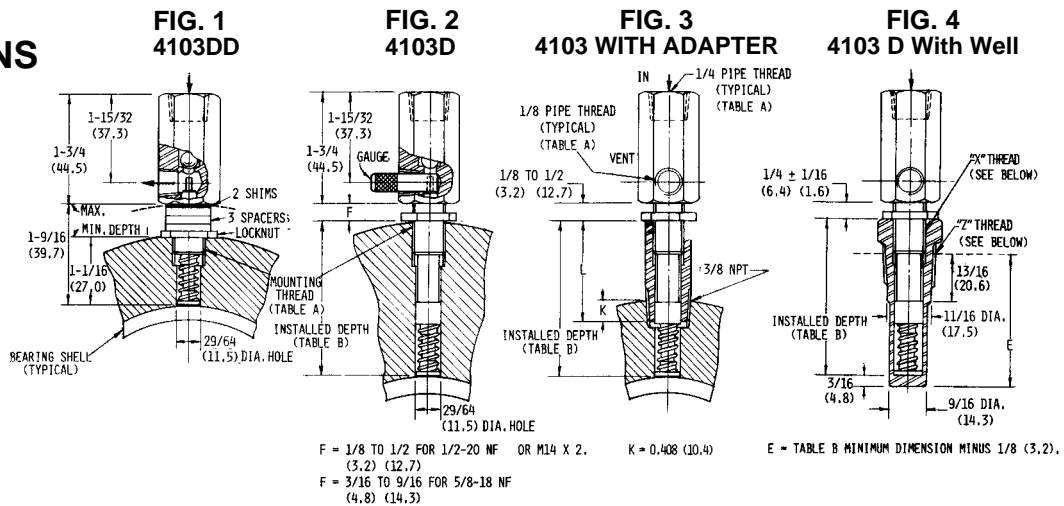

**TYPICAL APPLICATION**

FIG. 5

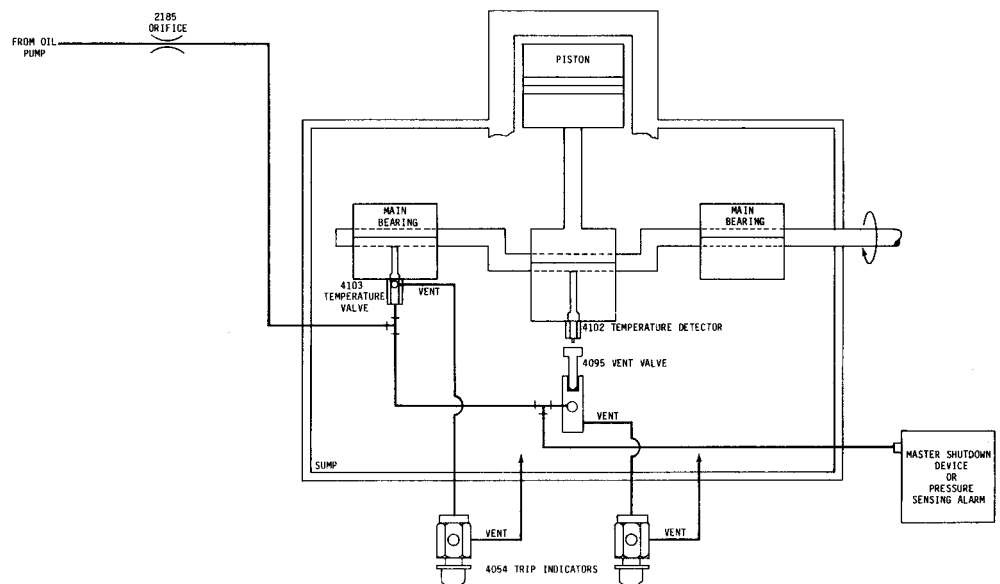

## HOW TO ORDER

When ordering please specify the following:

1. Indicate Model 4103.
2. Mounting Thread: 1/2-20 NF or 5/8-18 NF.
3. Installed Depth, see Table B.
4. Trip Temperature in deg. F: 174, 197, 217, 228, 253, 291, 324, or 343.
5. The following special features if required:
  - a. Stainless Steel Valve Ball (instead of Viton.)
  - b. Thermowells.
  - c. Model 6660L Adapter.
  - d. 6722 Gauge for Adjustment.
  - e. M14 X 2 metric Mounting Threads. Available from UK factory only.
  - f. 1/4BSP(Tr) Valve Port Thread (instead of NPT.) Available from UK factory only.

This unit may be ordered using the full description as shown above or by constructing a Model No. using the Model Code System.

## HOW TO ORDER REPLACEMENT FUSE RODS

When ordering please specify the following:

1. Fuse Rod Assembly Model 6710X.
2. Fuse Rod length; see Table B.
3. Trip Temperature in deg. F; see Table D.

**Thermowells** available, but must be ordered separately.

6721L 0 04  
 from Model Code Table B (4103 only)

Code No.	"X" Thread	"Z" Thread	Well Max. Pressure
0	1/2-20 UNF	1/2 NPT	3,5000 PSI
1	1/2-20 UNF	1/2 BSP (Tr)	
2	M14 x 2-6H	1/2 NPT	
3	M14 x 2-6H	1/2 BSP (Tr)	

7574L 0 04  
 from Model Code Table B (4103 only)

Code No.	"X" Thread	"Z" Thread	Well Max. Pressure
0	1/2-20 UNF	3/4 NPT	5,000 PSI
High Pressure Well 9859L is available - Consult Factory			(8,000 PSI)

## MODEL CODE SYSTEM

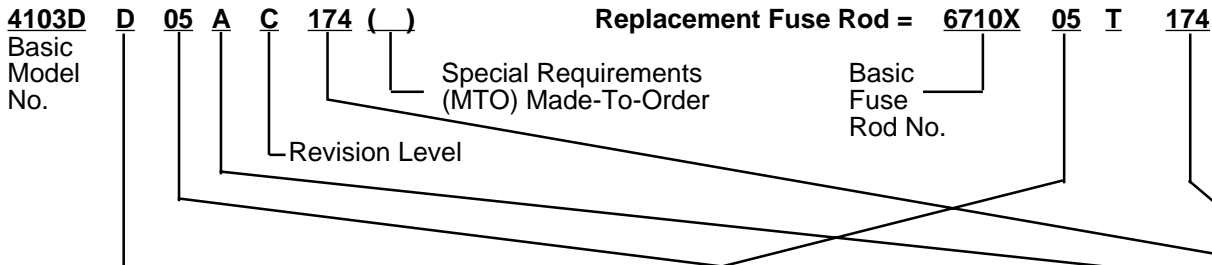

TABLE A Mounting Thread & Valve Port Thread				TABLE B Installed Depth & Fuse Rod				TABLE C Valve Ball		TABLE D Trip Temperature	
Basic Model No.	Code No.	Mounting Thread	Valve Port Thread	Code No. 4103D	Installed Depth Minimum *	Maximum *		Code No.	Material	°F	(°C)
4103D	D	1/2-20 NF	NPT	03	1-1/8(26.0)	1-9/16 (38.3)		A	Viton	174	(79)
	A **	M14 x 2	NPT	04	1-7/8(47.6)	2-1/4 (57.2)		B	Stainless Steel	197	(92)
	K **	M14 x 2	BSP(Tr)	05	2-3/8(58.2)	2-3/4 (70.0)				217	(103)
	L **	1/2-20 NF	BSP(Tr)	06	2-7/8(70.4)	3-1/4 (82.6)				228	(109)
				07	3-3/8(85.7)	3-3/4 (95.3)				253	(123)
				08	3-7/8(98.4)	4-1/4 (108.0)				291	(144)
				09	4-3/8(111.1)	4-3/4 (120.7)				324	(162)
				10	4-7/8(123.8)	5-1/4 (133.4)				343	(173)
				11	5-3/8(136.5)	5-3/4 (146.1)					
				12	5-7/8(149.2)	6-1/4 (158.8)					
				13	6-3/8(161.9)	6-3/4 (171.5)					
				14	6-7/8(174.6)	7-1/4 (184.2)					
				15	7-3/8(187.3)	7-3/4 (196.9)					
				16	7-7/8(200.0)	8-1/4 (209.6)					
				17	8-3/8(212.7)	8-3/4 (222.3)					
				18	8-7/8(225.4)	9-1/4 (235.0)					
				19	9-3/8(238.1)	9-3/4 (147.7)					
				20	9-7/8(250.8)	10-1/4 (260.4)					

= Non Standard Product, special charge may apply.

\* Dimensions in inches; millimeters in ( ).

\*\* Available from UK factory only.

AMOT designs and tests all its products to ensure that high quality standards are met. For good product life, carefully follow AMOT's installation and maintenance instructions; failure to do so could result in damage to the equipment being protected.

**NOTE:** Letters or numbers in the MTO space, other than nothing, A1 or AA, indicate the unit is built to special requirements and some of the other code numbers may not be valid. Check with the factory for full specifications of such models.

## MAINTENANCE

It is recommended that the overall safety system be checked monthly for proper functioning by simulating an unsafe condition.

AMOT recommends maintenance including visual inspection at the major overhaul of the engine or yearly if lacquering of the lube oil is observed. Excessive lacquering can cause sticking which impairs operation. Unscrew the Detector from the mounting hole and remove Fuse Rod Assembly (4) with a twisting motion. Hold it by the ends and visually examine the eutectic alloy area for exposed alloy. Visible alloy should be a clean fillet around the two brass sections of the Fuse Rod Assembly. Look for cracks in the brass. A stable Fuse Rod Assembly moves slightly showing no wear. Fuse Rod Assemblies should be replaced if the crimp section becomes loose.

Life expectancy of Fuse Rod Assemblies is five (5) years under normal operating conditions and proper maintenance.

If desired, maintenance of the Fuse Rod Assemblies themselves may include random sampling and test firing to ensure correct temperature.

**WARNING**  
**When unrestrained Fuse Rod Assemblies are heated, they fire with sufficient force to cause injury or damage. Be sure that the Fuse Rod is restrained or aimed in a safe direction.**

## FUSE ROD ASSEMBLY REPLACEMENT

When a Model 4103 Temperature Valve trips, it has detected excessive heat. Check for proper operating temperature of the oil and check the bearing for signs of distress to determine the source of the heat. To replace Fuse Rod Assembly (5), remove the entire Temperature Detector from the mounting hole and withdraw the expended Fuse Rod with the rod tip and Loading Spring (4). Insert the new Fuse Rod Assembly and reassemble the Temperature Detector with the Loading Spring fully seated on the Rod Tip. Reinstall the unit in the mounting hole and adjust the depth as described under installation.

## STATEMENT OF POLICY

AMOT Controls Corporation is ready to aid the user in the applications of Model 4103 Temperature Valves to the extent of its knowledge and experience. Decisions such as actual location of the installation, insertion length, details of machining, mounting of vent valves and connection to the safety system should only be made by the user after he has physically checked the equipment under consideration.

AMOT can be responsible only for proper operation of the devices providing they have been installed according to AMOT's instruction. AMOT cannot be responsible for improper adjustment, location, connections, or problems arising from stress concentration. Should there be any reservations or unresolved details concerning the application, the user should contact the manufacturer of the protected equipment for additional information.

## SERVICE PARTS

Replacement Fuse Rod Assemblies (5) are ordered by Basic Part No. 6710X plus the proper code numbers from Tables C & D of the Model Code System.

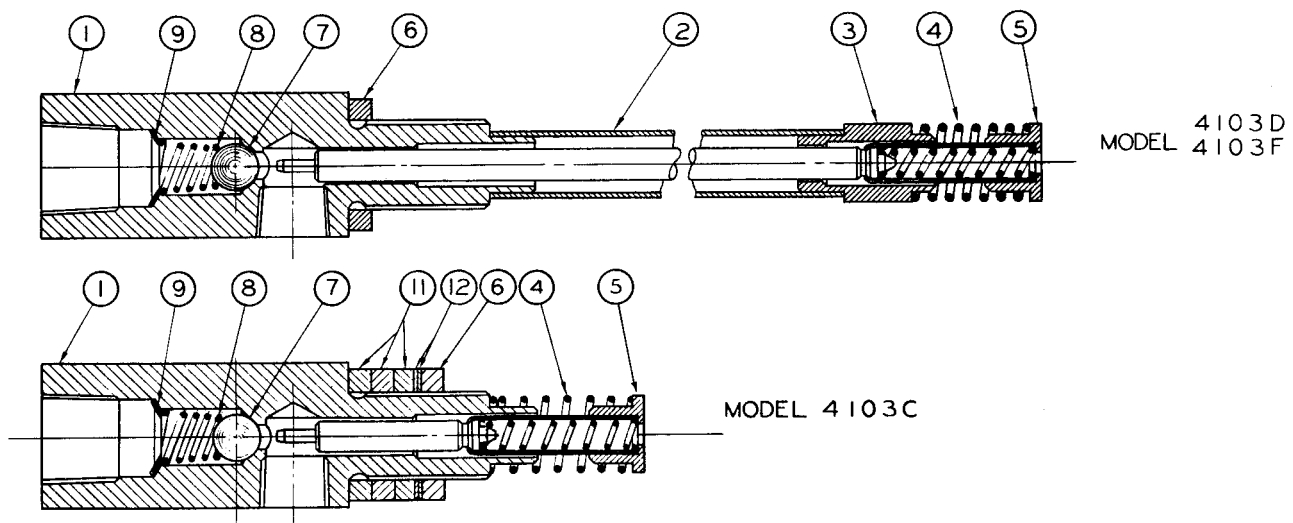

### AMOT USA

401 First Street  
Richmond, CA 94801  
Tel: +1 510 236-8300  
Fax: +1 510 234-9950

### AMOT

Western Way  
Bury St. Edmunds IP33 3SZ  
Suffolk England  
Tel: +44 1284 762222  
Fax: +44 1284 760256

### AMOT SINGAPORE

10 Eunos Road 8 # 12-06  
Singapore Post Centre  
Singapore 408600  
Tel: +65 6293 4320  
Fax: +65 6293 3307