



Model MPD

MPD Metal Particle Detector

NEW!
Patented Design



AMOT's MPD detects metal particles in lubrication fluids.

The MPD Must be used with an intrinsically safe control system in hazardous areas.

APPLICATIONS

AMOT's MPD Switch can detect and alert equipment operators of the presence of metal particles in non-conductive fluid lubrication systems (lube oil, transmission fluid, etc.). The MPD can be used with AMOT's MPD Controller or an alternate, approved controller. Common MPD applications would include the following:

■ RECIPROCATING EQUIPMENT

- ~ Gas Engines
- ~ Diesel Engines
- ~ Compressors

■ ROTATING EQUIPMENT

- ~ Gas Turbines
- ~ Steam Turbines
- ~ Transmissions and Gear Boxes
- ~ Pumps
- ~ Compressors

FEATURES / BENEFITS

- **UNIQUE GRID SENSING TECHNOLOGY**
 - ~ Detects metal particles, metal chips, and metal dust.
 - ~ Detects all conductive metal particles (including non magnetic metal particles).
 - ~ No moving parts.
- **DUAL SEAL WITH WEEP HOLE CONSTRUCTION**
 - ~ Meets API 614
 - ~ Meets National Electric Code
- **SEPARATE CONTROLLER AVAILABLE FOR USE WITH MPD**
 - ~ See AMOT form 1309, Model 8545B for MPD Controller.
 - ~ Complete Metal Particle Detector system available from AMOT.

ECONOMIC BENEFITS OF INSTALLING AMOT MPD SYSTEM

~ MPD makes maintenance proactive instead of reactive. MPD alerts equipment operators of metal particles in lubricating fluids caused by worn bearings, connecting rods, pistons, rings, camshafts or other metallic parts. Corrective maintenance can then be scheduled to **minimize costly down time**.

~ By alerting equipment operators of metal particles in lubricating fluids, MPD assists in the **prevention of unnecessary repairs and replacement of expensive parts**, i.e., replacement of a bearing instead of a crankshaft.

OPERATION

Operation of AMOT's Metal Particle Detector switch (MPD) is simple and straight forward. Process Fluid, such as lube oil or transmission fluid, enters at the top of the MPD's body. Fluid then travels through a perforated board containing a plated electrical grid on the board's top and bottom sides. Fluid exits through the bottom of the MPD body. (Refer to Figure 1.)

Activation of the MPD switch occurs when metal particles bridge the gaps on the MPD's electrical grid and complete a normally open (N.O.) electrical circuit to drive an alarm or shutdown relay. (Refer to Figure 2.)

INSTALLATION

For in depth installation instructions, refer to AMOT Form No. 1248 and Drawing No. 10956.

Installation of the MPD is accomplished in four (4) steps:

1. Locating where the MPD will be mounted.

The MPD must be located in a side stream of the lube oil / fluid system, after the pump but before the filter. (Refer to Figure 1).

2. Mounting the MPD.

Mount the MPD with the grid in a horizontal position. **It does not matter which process port is the IN port so long as the flow through the MPD is from top to bottom and the grid is on a horizontal plane.** Two 5/16-18 UNC mounting holes are cast into the MPD body. Isolation valves should be used as in Figure 1 to facilitate inspection and service of the MPD switch.

3. Piping the process fluid to the MPD.

When connecting the piping, never use excessive force to stop thread leakage. Apply a quality thread sealant such as Loctite™ Pipe Sealant to the MPD's pipe threads. Do not permit debris to enter the MPD while piping (this will set off the MPD).

CAUTION:

Flow to the MPD should be limited to prevent starving the equipment of oil (use an orifice, needle valve, etc.).

4. Making MPD electrical connections.

All wiring to and from the MPD should be done in accordance with the applicable electrical code. End Cap (22) should be removed (with a 1/2" S.A.E. drive ratchet) to access the MPD's terminal block, flying leads or plug connector (depending on the MPD connection option ordered).

SERVICE & MAINTENANCE

Refer to Figure 3, cross sectional.

Prior to servicing or maintaining the MPD:

Make sure all electricity is disconnected from the MPD.

Ensure all process pressure is relieved from the grid compartment before removing the MPD's end cap (block valve closed, bleed valve open).

AMOT MPD requires minimal maintenance. Recommended maintenance would include removal and replacement of the MPD's End Cap O-Rings (23), Grid O-Ring Seal (8), and Grid Board (2). Inspection of the aforementioned components should take place during the equipment's scheduled maintenance.

Multi Meter Grid Conductivity Test

Grid (2) should be inspected for signs of lacquering or residue build up which will interfere with the grid's ability to detect metal particles and complete the electrical circuit. AMOT recommends using a multi meter to test the grid's ability to complete an electrical circuit.

Remove End Cap (22) with a 1/2" S.A.E. drive ratchet. Pull the Grid (2) free of the MPD body (26) by hand. Use the multi meter to determine the grid's conductivity. Touch one multi meter probe to each of the MPD's grid pads. Short the grid out by placing a small metal object (such as a penny or screw) across the grid. If the grid will not short out, it must be replaced.

FIGURE 3: CROSS SECTIONAL

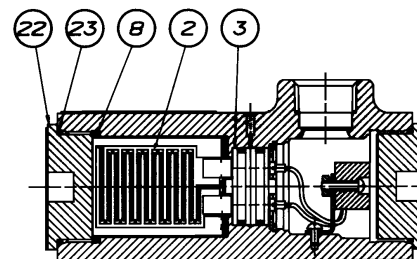

Recommended Spares / Service Parts Kit 10829X001

Ref. No.	Qty.	Part No.	Description
2	1	10831	Grid
23	2	11462L001	End Cap O-Ring, Viton
8	1	1919L001	Grid O-Ring Seal, Viton

FIGURE 1
MPD INSTALLATION DIAGRAM

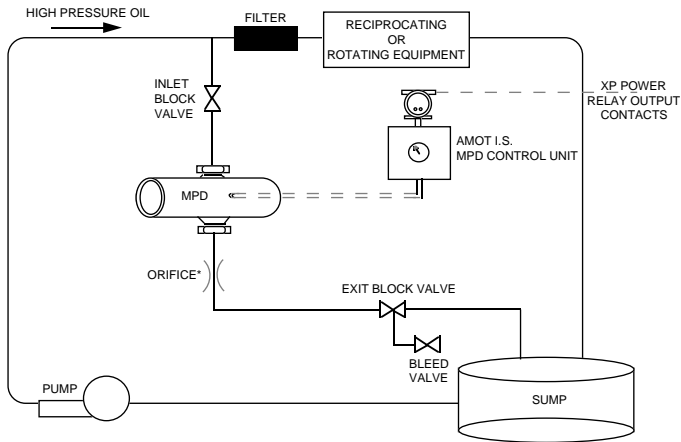

•Flow to the MPD should be limited to prevent starving the equipment of oil (use an orifice or other means of adequate restriction).

FIGURE 2
MPD SWITCH DIAGRAM

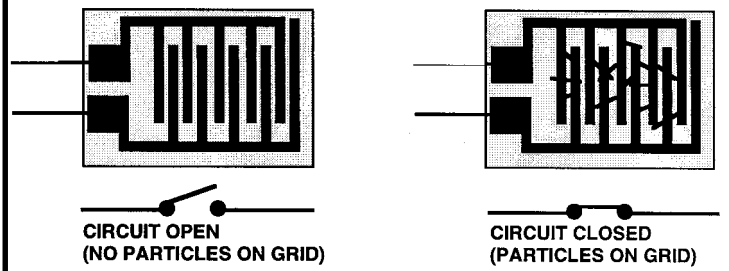

Metal particles gather on the MPD's Grid to complete an electrical circuit. Refer to right diagram.

DIMENSIONS

(Shown in inches, +/- .010)

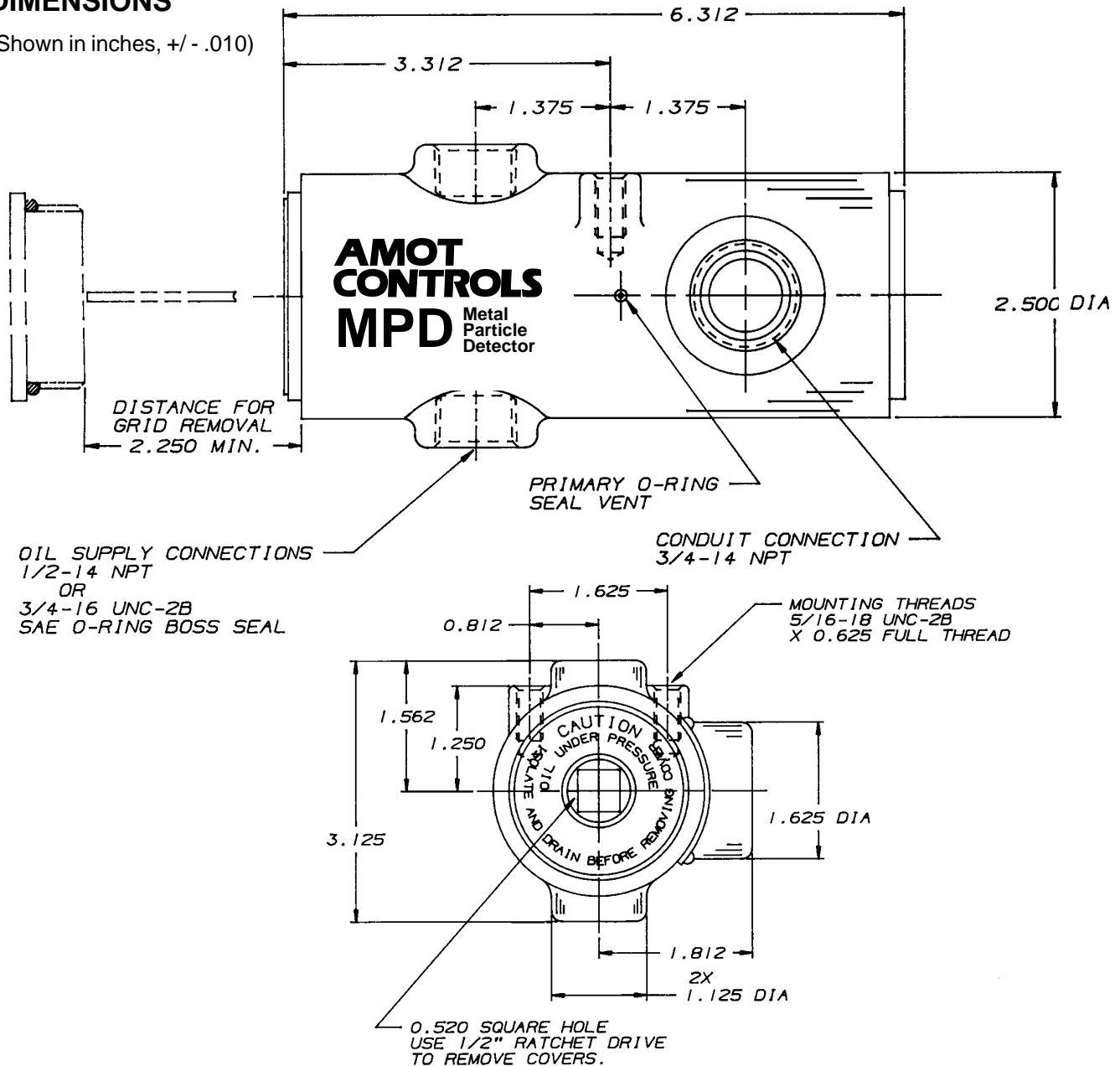

SPECIFICATIONS

Body & End Caps	316 Stainless Steel
Seals	Viton (Buna Optional)
Electrical Connections	Plated Tin
Grid Electrical Ratings	Refer to AMOT Drawing 10956
Flow Coefficient (C _v)	4.34
Flow of Oil at 60 psi	27 GPM
(180 SSU, Specific Gravity .90, No Restriction On Outlet)	
Temperature Rating	-10 to 400 deg. F (Viton)
	-55 to 225 deg. F (Buna)
Maximum Working Pressure	Standard: 200 psi
	High Pressure Version: 800 psi
Recommended Wire Gage	16 gauge
(Terminal Block Version)	
Lead Wire Gage	16 gauge
(Versions With Lead Wires)	
Approvals	UL Class 1, Groups A, B, C, & D
Only if installed per AMOT Drawing 10956 (Intrinsically Safe)	
Shipping Weight	7 lbs.

HOW TO ORDER

To order the MPD, construct the appropriate model number from the Model Code Table or specify the following information:

- 1) AMOT MPD Switch
- 2) Body Material (Stainless Steel); Table A.
- 3) Process Fluid Connection:
1/2" NPT, SAE, or BSP (PI); Table B.
- 4) Electrical Conduit Port Connection (3/4" NPT);
Table C.
- 5) Electrical Connection Type:
Terminal Plug, Terminal Block, or 18" Wire Leads;
Table D.
- 6) Seal Material:
Viton or Buna; Table E.

AMOT can also supply a UL approved control box for use with the MPD. Contact AMOT or your local representative for details.

MODEL CODING TABLE

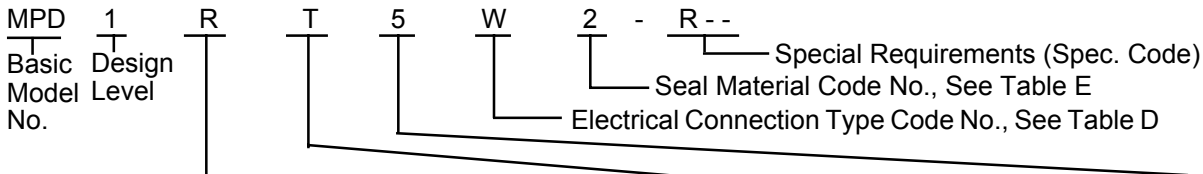

TABLE A Product Type Code No.		TABLE B Oil Port Connection Code No.			TABLE C Electrical Conduit Port Code No.	
Stainless Steel	R	1/2	NPT	T	3/4 NPT	5
Stainless Steel, High Pressure	P	1/2	SAE	W		
		1/2	BSP (P1)	U		

TABLE D Electrical Connection Type Code No.		TABLE E Seal Material Code No.	
Electrical Connection	Code No.	Seal Material	Code No.
Wire Leads, 18"	W	Viton	2
Terminal Plug	P	Buna N	1
Terminal Block	T		

= Non Standard

The AMOT MPD product is a tool to assist in the monitoring / detection of undesirable conditions which may result in reduced engine life or catastrophic failure. Like other monitoring or engine life diagnostic devices / tools, it is not guaranteed to increase engine life and / or eliminate catastrophic failure. The MPD product is primarily a random oil sampling device which may detect the presence of metal particulates in the lubrication oil. AMOT recommends using the MPD in conjunction with good preventative maintenance practices and other bearing temperature sensors, etc. It is the user's responsibility to select the appropriate MPD grid which determines the MPD's sensitivity in detecting metal particulate.

AMOT USA
8824 Fallbrook Dr
Houston, TX 77064
Tel: +1 281 940-1800
Fax: +1 281 668-8802

AMOT
Western Way
Bury St. Edmunds IP33 3SZ
Suffolk England
Tel: +44 1284 762222
Fax: +44 1284 760256

AMOT SINGAPORE
10 Eunos Road 8 # 12-06
Singapore Post Centre
Singapore 408600
Tel: +65 6293 4320
Fax: +65 6293 3307