

Pneumatic Control System Accessories

Models 2185, 2690, 2760,
2768, 2790B and 4125

Overview

All of the accessories shown are for use with other AMOT safety and sequencing components in any pneumatic control systems.

Product Description

Model 2185 – Used to restrict flow in timing circuits or used to prevent damage due to sudden application of pressure. Available in multiple diameters.

Model 2690 – Used in timing circuits in conjunction with the 2185 orifice. It is used to delay the pressure build up required to open or pressure loss to close a valve.

Model 2760 – Used in circuits to control the direction of flow.

Model 2768 – Used to dump pressure quickly on devices with large volumes such as valve bonnets or long tubing runs.

Model 2790B – Enables continuous pressurization of a single device in a circuit as the pressure transitions from one source to a different source.

Model 4125 – Used on vent ports, it allows flow in a single direction to prevent dirt, corrosive atmospheres, and insects from entering the control systems.

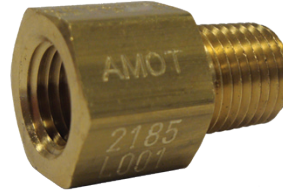

**Model 2185
Orifice**



**Model 2690
Accumulator**



**Model 2760
Check Valve**



**Model 2768
Quick Release Valve**

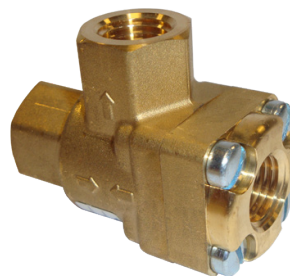

**Model 2790B
Shuttle Valve**



**Model 4125
Vent Closure**

amot

www.amot.com

Pneumatic Control System Accessories



2185 Orifice

Specification

Flow coefficient	See "How to order" for details	
Material	See "How to order" for details	
Maximum pressure	20.68 bar	(300 psi)
Net weight	170.1 g	(6 oz)

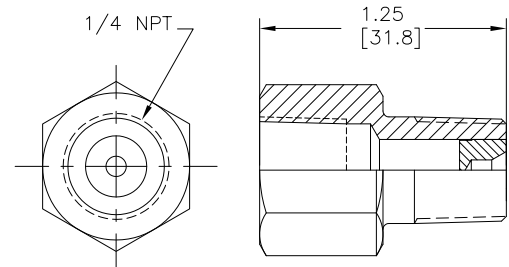

2690 Accumulator - 18 cu. in.

Specification

Material	2690L001	Stainless steel
	2690L100	Stainless steel with material certification
Threading	1/4 - 18 NPT	
Max. pressure	20.68 bar	(300 psi)
Net weight	170.1 g	(6 oz)

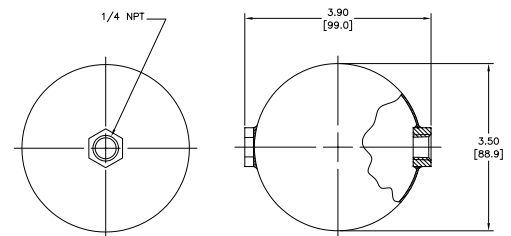

2760 Check Valve

Specification

Material	7/8 brass hex.	
Max. pressure	20.68 bar	(300 psi)
Min. pressure to open	0.14 bar	(2 psi)
Flow coefficient	Cv = 0.03	(Kv = 0.026)
Net weight	170.1 g	(6 oz)
Threading	1/4 - 19 BSP (PL) both ends	

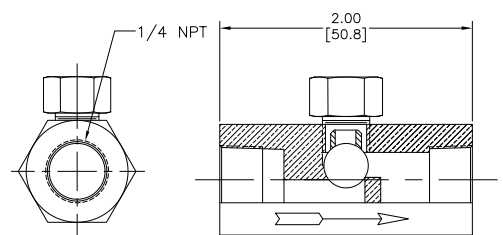

Pneumatic Control System Accessories



2768 Quick Release Valve

Specification

Max. pressure	17.2 bar	(250 psi)
Differential to release	0.34 bar	(5 psi)
Flow coefficient	In to out	Cv = 2.5 (Kv = 2.15)
	Out to exhaust	Cv = 2.0 (Kv = 1.72)
All ports	3/8 NPT	
Net weight	0.34 kg	(3/4 lb)
Shipping weight	0.45 kg	(1 lb)

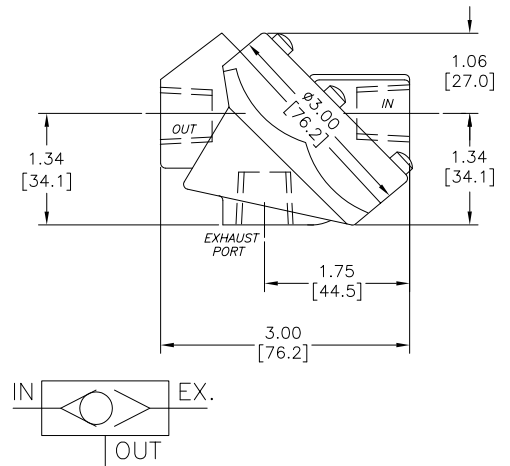

2790B Shuttle Valve 1/4 NPT

Specification

Material	Brass	
Max. pressure	10.3 bar	(150 psi)
Pressure differential to operate	0.34 bar	(5 psi)
Flow coefficient	Cv = 1.6	(Kv = 1.38)
Net weight	0.45 kg	(1 lb)
Threading	1/4 - 18 NPT	

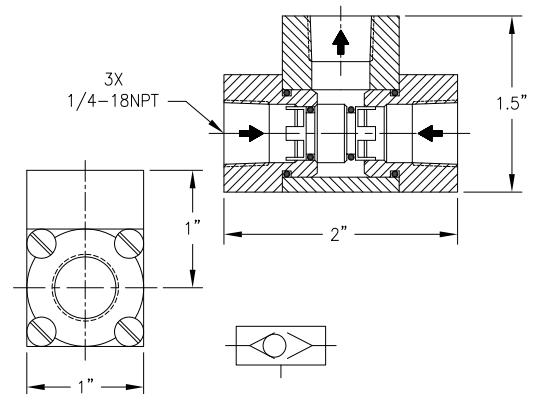

4125 Vent Closure for 1/4 NPT Thread

Specification

Body material	Plastic
Valve material	Silicon rubber
Thread	1/4" NPT

Used for excluding dirt, corrosive atmospheres, and insects from critical internal working parts of controls. (Note: This is not a "breather", It will exhaust only.)

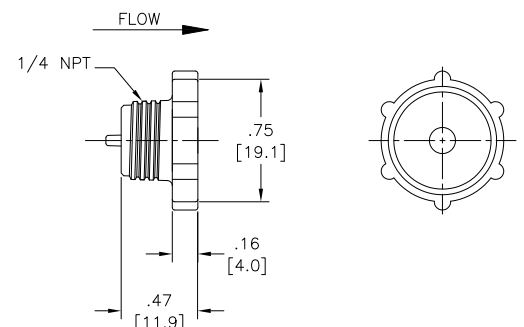

Pneumatic Control System Accessories

How to order

Use the table below to select the model code of your pneumatic control system accessory

Example Model Code	2185L	10	3	Comments				
Orifice	2185L			Basic model code				
Material and Thread				Material	Thread			
				00	Brass	1/4 NPT*		
				01	Nickle Plated Brass	1/4 NPT*		
				10	Aluminum	NPT		
				11	Aluminum	BSP (PL)		
				20	Stainless Steel	NPT		
				21	Stainless Steel	BSP (PL)		
Size and Flow Coefficient				Orifice Diameter		Flow Coefficient		
				Inch	mm	Cv	Kv	
				1	0.014	0.34	0.004	0.0034
				2	0.031	0.8	0.020	0.017
				3*	0.125	3.18	0.470	0.404
				4*	0.040	1.0	0.030	0.026
	5	0.062	1.57	0.100	0.086			

*003 and 004 are only available in 1/4 BSP(PL)

Product	Model Code		
Accumulator - 18 cu. In.	2690L001	Stainless Steel	Used to delay the pressure build up required to open or pressure loss required to close a valve.
	2690L100	Stainless Steel with material certification	
Check Valve	2760	Used in circuits to dump pressure quickly or control the direction of flow.	
Shuttle Valve 1/4 NPT	2790B	Enables continuous pressurization of a single device in a circuit as the pressure transitions to a different source.	
Quick Release Valve	2768	Used to dump pressure quickly on devices with large volumes such as valve bonnets or long tubing runs.	
Vent Closure For 1/4 NPT Threaded	4125	Blocks dirt, corrosive atmospheres, and insects from entering the vent valve of a control system.	

Europe and Africa

AMOT
Western Way
Bury St Edmunds
Suffolk, IP33 3SZ
England

Tel +44 (0) 1284 762222
Fax +44 (0) 1284 760256
Email info@amot.com

AMOT Controls GmbH
Rondenbarg 25
22525 Hamburg
Germany

Tel +49 (0) 40 8537 1298
Fax +49 (0) 40 8537 1331
Email germany@amot.com

AMOT Russia
#34 Shabolovka Street
Building 2
Moscow 115419
Russia

Tel: +7 495 617 12 93
Fax: +7 495 913 97 65

Americas

AMOT USA
8824 Fallbrook Dr
Houston
TX 77064
USA

Tel: +1 (281) 940 1800
Fax +1 (713) 559 9419
Email sales@amotusa.com

Asia and Australasia

AMOT Shanghai
Rm A308 Building A8
Jiahua Business Center
808 Hongqiao Road
Shanghai 200030
China

Tel +86 (0) 21 6447 9708
Fax +86 (0) 21 6447 9718
Email shanghai@amot.com

AMOT Singapore
10 Eunos Road 8 #12-06
Singapore Post Centre
Singapore 408600

Tel +65 6408 6265
Fax +65 6293 3307
Email singapore@amot.com