

# Thermostatic Control Valves

## Model E

### Typical applications

- Lubricating oil temperature control
- Jacket water high temperature (HT)
- Secondary water low temperature (LT)
- Heat recovery
- Water saving applications
- Boiler inlet temperature control
- Co-generation, cooling towers
- Temperature mixing or diverting
- Engine and compressor cooling system

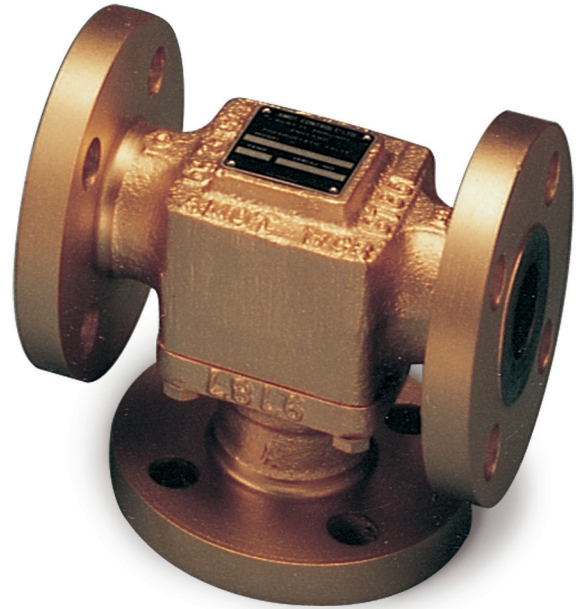

**Model E**  
**Thermostatic Control Valve**

### Key benefits

- No external power source required - simple, low cost installation
- No user setting needed - 'fit and forget' solution
- Small number of parts - simple maintenance and low cost of ownership
- Robust design capable of high vibration and shock applications
- Easy installation, operates in any mounting position
- Automatic self-sensing control with positive proportional valve action

### Accreditations

- PED Suitable for Group 1 & 2 liquids (Ensure materials are compatible)
- ATEX  11 2 G X
- CE Complies with all relevant EU directives

### Key features

- Flow rates of 9 - 17m<sup>3</sup>/hr (40 - 75 US gpm)
- Combinations available: Housings in cast iron, bronze, carbon steel, stainless steel
- DN32 and DN40 (1 1/4" and 1 1/2") pipe sizes
- Threaded and flanged connections
- Tamper-proof temperature settings from 30°C to 113°C (85°F to 235°F)
- Pressure ratings up to 68 bar (1000 psi)

**amot**

[www.amot.com](http://www.amot.com)

# Thermostatic Control Valves - Model E

---

## Contents

---

Overview .....	3
Applications .....	4
Valve Characteristics .....	4
Pressure drop .....	4
Flow coefficient .....	5
Available versions .....	6
Temperature & element characteristics .....	6
Element type and seal material .....	6
Specification .....	6
How to order .....	7
Service kits .....	8
Dimensions & Weights .....	9

# Thermostatic Control Valves - Model E

---

## Overview

---

AMOT model E thermostatic valves are available in a wide selection of sizes and settings to fill a multitude of fluid temperature control requirements. These valves may be mounted in any position and use the proven expanding wax principle to actuate the 3-way temperature element assemblies. The model E valves may be used for diverting, mixing or 2-way water saving

service. They make very economical temperature limiting valves to prevent scalding in home, motel or hotel hot water supply systems. Radiant heating systems can use these valves in limiting water temperature to prevent surface cracking and overheating of plastic piping. Other applications include electronic and battery cooling circuits, pump temperature relief valves etc.

---

### Available housing materials

- Bronze
- Cast iron
- Stainless steel
- Carbon steel

### Element materials

- Bronze, brass and stainless steel
- Nickel plated/Stainless steel
- Stainless steel

### Seal materials

- Buna-N/Nitrile
- Viton
- Neoprene

### Manual override

If desired, AMOT Model E thermostatic valves can be supplied with a manual override which allows the user to direct flows through Ports A and C.

---

### Leak holes

In some applications, it is necessary to have leak holes drilled in the element to ensure a small flow between ports A and C. Leak holes are available in sizes ranging from 1.6mm to 6.4mm ( $1/16''$  to

$1/4''$ ). Please refer to the Temperature Control Valve Selection Guide to determine the hole size required for specific applications.

---

### Temperature settings

A wide selection of element materials, seals and temperatures are available. Follow the equipment manufacturers' guidelines for heating/cooling systems.

Temperature settings are available from 30°C to 113°C (85°F to 235°F). Refer to the Temperature & Element Characteristics table on page 6 for specific temperature settings. In general the temperature quoted is the nominal operating temperature in diverting mode on water systems.

For long life, AMOT valves should not be operated continuously at temperatures in excess of 14°C (25°F) of their maximum continuous rating. If this condition is anticipated then consult AMOT for suitable alternatives.

For mixing and oil circuits the temperature may be one to two degrees higher due to flow, viscosity and other system parameters.

Elements and seals are available in a variety of materials. These materials are suitable for most applications. Please refer to the Temperature Control Valve Selection Guide for material compatibility information.

# Thermostatic Control Valves - Model E

## Applications

### Diverting Applications

When valves are used for diverting service, the inlet is Port A (temperature sensing port), with Port C being connected to the cooler, and Port B connected to the cooler by-pass line.

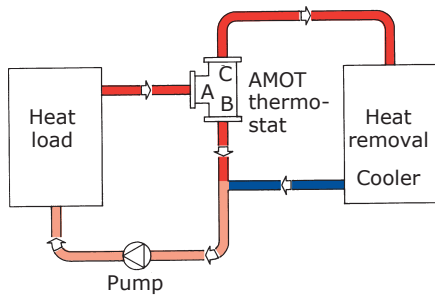

### Mixing Applications

When valves are used for mixing service, Port C is the cold fluid inlet port from the cooler, Port B is the hot by-pass fluid inlet, and Port A the common outlet. Port A is the temperature sensing port and will mix the hot and cold fluids in the correct proportion so as to produce the desired outlet temperature leaving Port A.

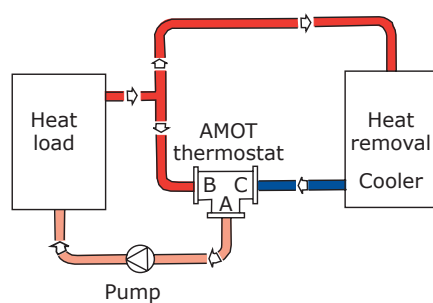

### 2-way Water Saving Applications

Valve as shown maintains minimum flow through cooler to conserve water. Requires internal leak hole to permit small flow for sensing.

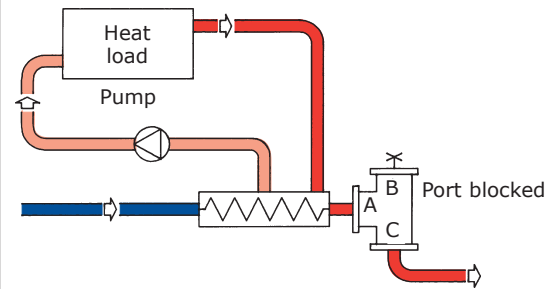

## Valve characteristics

### Pressure drop (Metric units)

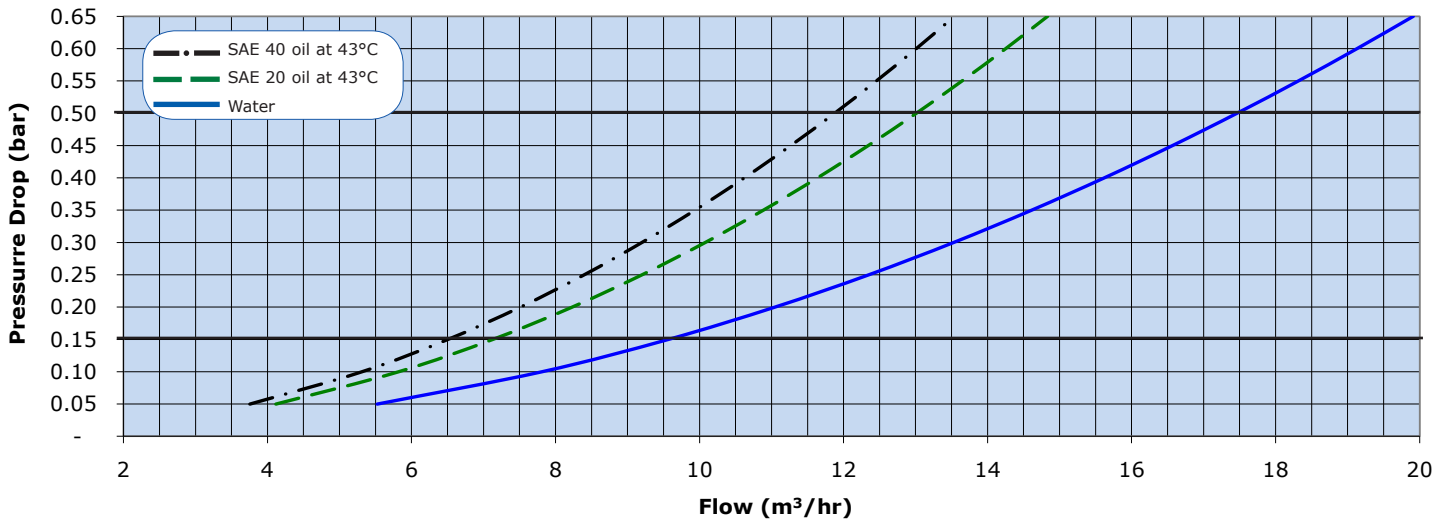

AMOT thermostatic valves are designed to produce minimal pressure drop. The normal recommendation in sizing the valves is to select a pressure drop between 0.14 to 0.5 bar (2 to 7 psi).

# Thermostatic Control Valves - Model E

## Valve characteristics

### Pressure drop (English units)

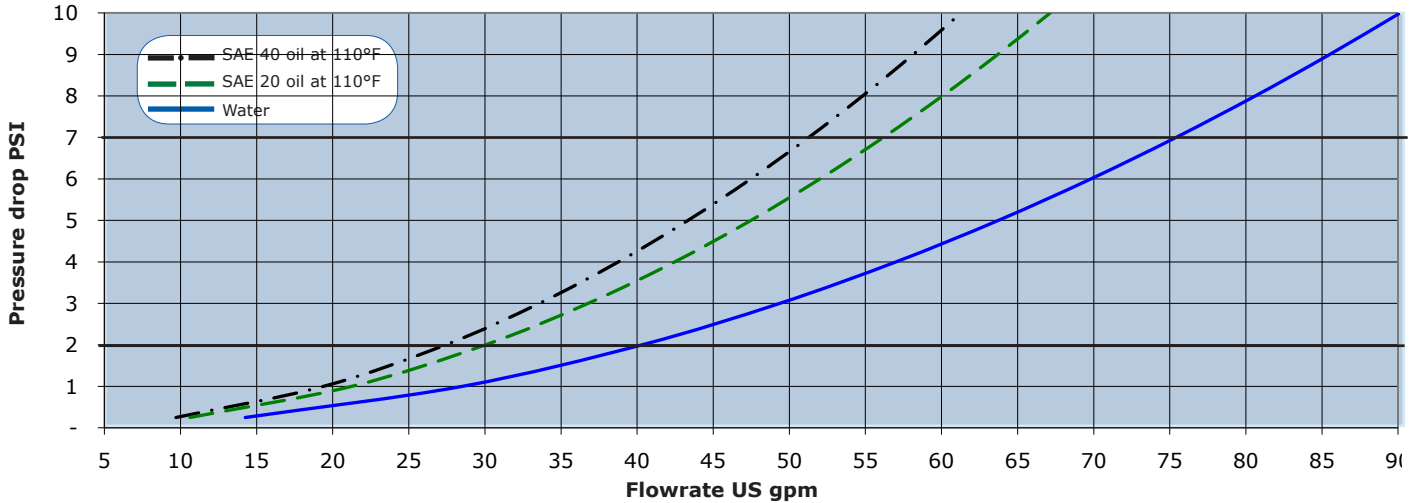

AMOT thermostatic valves are designed to produce minimal pressure drop. The normal recommendation in sizing the valves is to select a pressure drop between 0.14 to 0.5 bar (2 to 7 psi).

### Flow coefficient

Flow coefficients (calculated)		
Size	Kv	Cv
1 1/4 E	24.7	28.5
1 1/2 E	24.7	28.5

**Kv** is the flow coefficient in metric units. It is defined as the flow rate in cubic meters per hour (m<sup>3</sup>/h) of water at a temperature of 16° Celsius with a pressure drop across the valve of 1 bar. The basic formula to find a valve's Kv is shown below:

$$DP = \left(\frac{Q}{Kv}\right)^2 SG \quad Q = Kv \sqrt{\frac{DP}{SG}}$$

Q = Flow in m<sup>3</sup>/hr  
 DP = Pressure drop (Bar)  
 SG = Specific gravity of fluid (Water = 1.0)  
 Kv = Valve flow coefficient

**Cv** is the flow coefficient in English units. It is defined as the flow rate in US Gallons per minute (gpm) of water at a temperature of 60° Fahrenheit with a pressure drop across the valve of 1 psi. The basic formula to find a valve's Cv is shown below:

$$DP = \left(\frac{Q}{Cv}\right)^2 SG \quad Q = Cv \sqrt{\frac{DP}{SG}}$$

Q = Flow in US gallons  
 DP = Pressure drop (psi)  
 SG = Specific gravity of fluid (Water = 1.0)  
 Cv = Valve flow coefficient

# Thermostatic Control Valves - Model E

## Valve characteristics continued

### Available versions

Cast iron	Bronze	Steel	Stainless steel
Threaded	Threaded	Threaded	Threaded
1 1/4 EL	1 1/4 EO	None	None
1 1/2 EL	1 1/2 EO		
Flanged	Flanged	Flanged	Flanged
1 1/2 EF	1 1/2 EF	1 1/2 EF	1 1/2 EF
1 1/2 EM	1 1/2 EM	1 1/2 EM	1 1/2 EM

### Temperature & element characteristics

Code	Control temp.		Rated range				Max cont. temp.	
	°C	°F	Crack open		Full open		°C	°F
085	30	85	26	79	33	93	65	149
095	35	95	30	86	40	104	50	122
100	38	100	33	92	42	108	75	167
110	43	110	38	100	47	117	82	180
120	49	120	44	112	55	131	88	191
130	54	130	49	120	60	140	95	203
140	60	140	54	130	66	151	99	210
150	65	150	60	140	71	160	104	219
160	71	160	66	150	77	170	110	230
170	76	170	72	163	82	180	115	239
175	80	175	77	170	85	185	115	239
180	82	180	79	175	87	190	118	245
190	87	190	85	185	93	200	118	245
200	93	200	90	194	100	212	110	230
205	96	205	93	200	103	218	110	230
215	101	215	107	225	122	253	123	254
225	107	225	101	214	114	237	120	248
235	113	235	107	225	113	253	124	257

### Element type and seal material

Code	Valve model	Element type	Description	Seals
01	EL/EF/EO	5435X	Standard element	Buna N/Nitrile
02	EL/EF/EO	5435P	Nickel plated	Viton
03	EL/EF/EO	5435X	Standard Element	Viton
04	EL/EF/EO	5435X	Nickel plated	Buna N/Nitrile
05	EL/EF/EO	5435P	Standard Element	Neoprene
07	EM	9831X	Standard manual override element	Buna N/Nitrile
07	EMSK/EMRK	10912X	Standard manual override element	Buna N/Nitrile
08	EM	9831P	Plated manual override element	Viton
08	EMSK/EMRK	10912P	Plated manual override element	Viton
09	EL/EF/EO	5435P	Nickel plated	Neoprene
11	EM	9831X	Standard manual override element	Viton
11	EMSK/EMRK	10912X	Standard manual override element	Viton
14	EM	9831X	Standard manual override element	Neoprene
14	EMSK/EMRK	10912X	Standard manual override element	Neoprene

## Specification

<b>Flow rate</b>		9 - 17m <sup>3</sup> /hr	(40 - 75 US gpm)	
<b>Body materials &amp; pressure ratings</b>	Cast iron	10 bar (145 psi)	(1 1/2 EL 24 bar 355 psi)	
	Bronze	10 bar	(145 psi)	
	Steel/Stainless steel	ANSI 150 lb	16 bar	(230 psi)
		ANSI 300 lb	45 bar	(660 psi)
	ANSI 600 lb	68 bar	(1000 psi)	
<b>Seal materials</b>	Nitrile/Buna N, Viton, Neoprene			
<b>Mounting position</b>	Any orientation			
<b>Ports</b>	Below nominal temperature	Ports A and B connected		
	Above nominal temperature	Ports A and C connected		
<b>Port connections</b>	Threaded	40 mm	(1 1/2")	
	Flanged	40 mm	(1 1/2") nom. bore	
<b>Valve sizes (nominal bore)</b>	32, 40 mm		(1 1/4", 1 1/2")	
<b>Recommended pressure drop</b>	0.14 to 0.5 bar		(2 to 7 psi)	
<b>Control temperatures</b>	30°C - 113°C		(85°F to 235°F)	

# Thermostatic Control Valves - Model E

## How to order

Use the tables below to select the unique specification of your E valve.

Example	1 1/2	EL	C	W	120	03	-0	-AA		Comments
									<b>Valve Size</b>	
Valve Size	1 1/4								32 mm 1 1/4"	
	1 1/2								40 mm 1 1/2"	
									<b>Valve Model</b>	
Valve Model		EF							Flanged Connections	
		EM							Flanged Connections with Manual Override	
		EL							Threaded Connections	
		EO							Threaded Connections	
									<b>Valve Body Material</b>	
Valve Body Material			B						Bronze	EO only
			C						Cast Iron	EL only
			R						Stainless Steel	EF/EM only
			S						Carbon Steel	EF/EM only
									<b>Port Connection</b>	
Port Connection				A					Flanged AMOT Metric #1 - DIN 2501 ND6	
				B					Flanged EN 1092 PN10	
				C					Flanged EN 1092 PN16	
				F					Flanged ANSI 125 lb	Cast Iron & Bronze only
				H					Flanged ANSI 300 lb	Steel and Stainless Steel only
				J					Flanged 150 lb	Steel and Stainless Steel only
				K					Flanged ANSI 600 lb	Steel and Stainless Steel only
				T					Threaded NPT to ANSI B2.1	
				U					Threaded BSP (PL) to BS 21	
				V					Threaded BSP (TR) Japanese (JIS)	
				W					Threaded to SAE J5 14H	Straight thread, O-ring seal
									<b>Control Temperature</b>	
Control Temperature					085				30°C (85°F)	
					095				35°C (95°F)	
					100				38°C (100°F)	
					110				43°C (110°F)	
					120				49°C (120°F)	
					130				54°C (130°F)	
					140				60°C (140°F)	
					150				65°C (150°F)	
					160				71°C (160°F)	
					170				76°C (170°F)	
					175				80°C (175°F)	
					180				82°C (180°F)	
					190				87°C (190°F)	
					200				93°C (200°F)	
					205				96°C (205°F)	
				215				101°C (215°F)		
				225				107°C (225°F)		
				235				113°C (235°F)		
									<b>Element &amp; Seal Material</b>	<b>Valve Models</b>
Element & Seal Material					01				Standard, Buna N/Nitrile	EL/EF/EO
					02				Nickle Plated, Viton	EL/EF/EO
					03				Standard, Viton	EL/EF/EO
					04				Nickle Plated, Buna N/Nitrile	EL/EF/EO
					05				Standard, Neoprene	EL/EF/EO
					07				Standard w/ MO, Buna N/Nitrile	EM or EMSK or EMRK
					08				Nickle Plated w/ MO, Viton	EM or EMSK or EMRK
					09				Nickle Plated, Neoprene	EL/EF/EO
					11				Standard w/ MO, Viton	EM or EMSK or EMRK
					14				Standard w/ MO, Neoprene	EM or EMSK or EMRK
									<b>Leakhole Size</b>	
Leakhole Size								-0	None	
								-A	3.2 mm (1/8")	
								-B	6.4 mm (1/4")	
								-C	4.8 mm (3/16")	
								-D	1.6 mm (1/16")	
									<b>Customer Special Requirements</b>	
Customer Special Requirements								-AA	Standard Product	
								-***	Customer Special Code	

# Thermostatic Control Valves - Model E

## Service kits

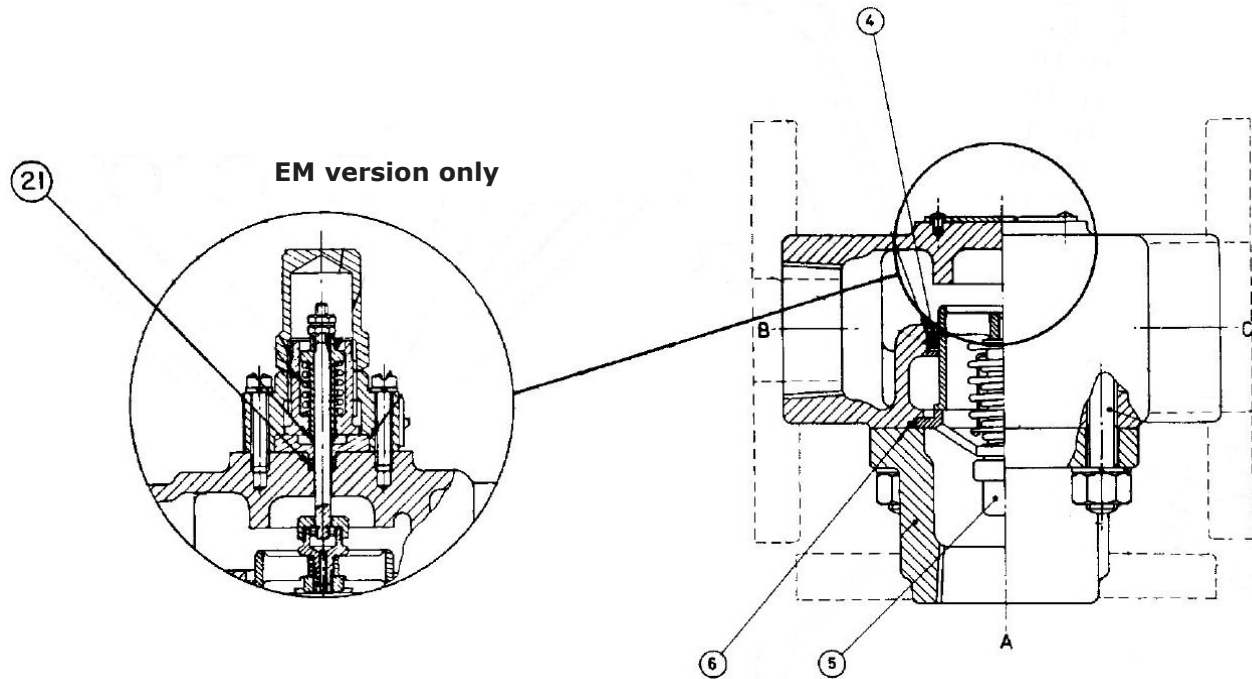

For models EL, EF (except EFSK, EMSK), Viton Seals			
Ref no.:	Qty	Description	Part no.
4	1	O-ring - Viton	1919L001
5	1	Element assembly, specify temperature in °F	5435X-(temp)
6	1	O-ring (after serial no. A801)	11090L002

For models EF, EL, EO (except EFSK, EMSK), Buna N/Nitrile Seals			
Ref no.:	Qty	Description	Part no.
4	1	O-ring, Buna N/Nitrile	1919
5	1	Element assembly specify temp. in °F	5435X-(temp)
6	1	O-ring Buna N/Nitrile (after serial no. A801)	11090L001

For models EFRK/EFSK, Viton, Buna N/Nitrile Seals			
Ref no.:	Qty	Description	Part no.
4	1	O-ring, Buna N/Nitrile	1919
4	1	O-ring, Viton	1919L001
5	1	Element assembly, specify temp. in °F	5435X-(temp)
6	1	Gasket	10899

For model EMRK and EMSK, Viton, Buna N			
Ref no.:	Qty	Description	Part no.
4	1	O-ring, Buna N	1919
4	1	O-ring, Viton (brown)	1919L001
5	1	Element assembly for EMRK/EMSK, specify temperature in °F	10912X-(temp)
5		Element assembly for EM, specify temperature in °F	9831X-(temp)
6	1	Gasket	10899
21	1	Stem seal, Buna N/Nitrile	11152L001
21	1	Stem seal, Viton (brown)	1152L002

# Thermostatic Control Valves - Model E

## Dimensions and weights

### Model 1<sup>1</sup>/<sub>2</sub> EL/EO

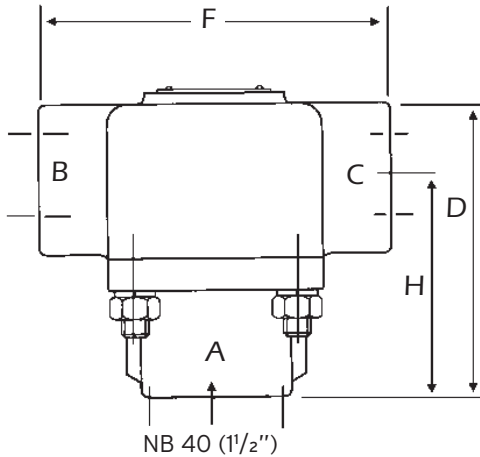

### Dimensions mm (inches)

Dimension	1 <sup>1</sup> / <sub>4</sub> EF	1 <sup>1</sup> / <sub>2</sub> EF	1 <sup>1</sup> / <sub>2</sub> EFSJ/ 1 <sup>1</sup> / <sub>2</sub> EFRJ	1 <sup>1</sup> / <sub>2</sub> EFSH/ 1 <sup>1</sup> / <sub>2</sub> EFRH	1 <sup>1</sup> / <sub>2</sub> EL/ 1 <sup>1</sup> / <sub>2</sub> EO
F	175 (6 7/8)	178 (7)	178 (7)	203 (8)	156 (6.2)
H	3 29/32 (99)	4 (101)	4 (101)	120 (4.8)	96 (3.8)
D		-	-	-	130 (5.2)

### Model 1<sup>1</sup>/<sub>4</sub> EF, 1<sup>1</sup>/<sub>2</sub> EF/EM

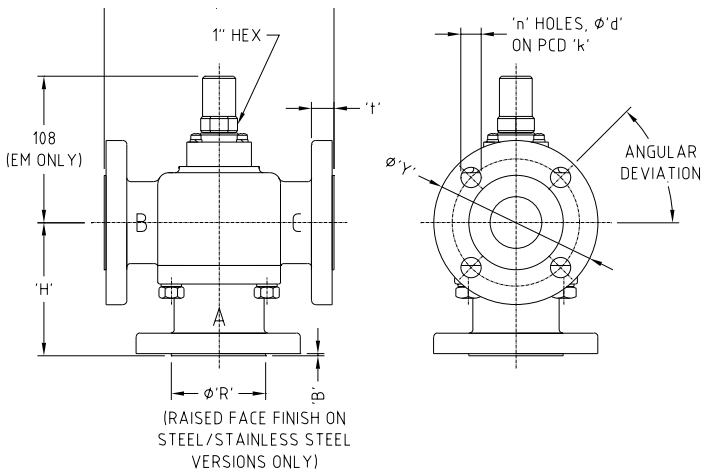

### Flange sizing mm (inches)

Flange	ØY	t	n	PCD K	Ø d	Ø R	B
PN6	130 (5.2)	18 (0.72)	4 (0.16)	100 (4)	14 (0.56)	80 (3.2)	2 (0.08)
PN10 and PN16	150 (6)	18 (0.72)	4 (0.16)	110 (4.4)	18 (0.72)	88 (3.5)	2 (0.08)
ANSI 125lb	127 (5)	18 (0.72)	4 (0.16)	98.4 (3.9)	15.88 (0.6)	-	-
ANSI 150lb	127 (5)	18 (0.72)	4 (0.16)	98.4 (3.9)	15.88 (0.6)	73 (2.9)	1.6 (0.06)
ANSI 300lb	155.6 (6.2)	20.57 (0.8)	4 (0.16)	114.3 (4.6)	22.23 (0.9)	73 (2.9)	1.6 (0.06)

See 'Port Connection' table in 'How to order' check list (page 7) for connection options

### Weight in kg (lbs)

Material	1 <sup>1</sup> / <sub>4</sub> 1 <sup>1</sup> / <sub>2</sub> EF	1 <sup>1</sup> / <sub>2</sub> EFSJ	1 <sup>1</sup> / <sub>2</sub> EFSH	1 <sup>1</sup> / <sub>2</sub> EFSK	1 <sup>1</sup> / <sub>2</sub> EL/EO
Weight	9 (20)	12 (26.5)	14 (30)	16 (35)	5 (11)

## Americas

---

AMOT USA  
8824 Fallbrook Dr  
Houston  
TX 77064  
USA

Tel: +1 (281) 940 1800  
Fax +1 (713) 559 9419  
Email sales@amotusa.com

## Asia and Australasia

---

AMOT Shanghai  
Rm 4102 - 4104 United Plaza  
1468 Nanjing Road West  
Shanghai 200040  
China

Tel +86 (0) 21 6279 7700  
Fax +86 (0) 21 5237 8560  
Email shanghai@amot.com

AMOT Singapore  
10 Eunos Road 8 #12-06  
Singapore Post Centre  
Singapore 408600

Tel +65 6408 6265  
Fax +65 6293 3307  
Email singapore@amot.com

## Europe and Africa

---

AMOT  
Western Way  
Bury St Edmunds  
Suffolk, IP33 3SZ  
England

Tel +44 (0) 1284 762222  
Fax +44 (0) 1284 760256  
Email info@amot.com

AMOT Controls GmbH  
Rondenbarg 25  
22525 Hamburg  
Germany

Tel +49 (0) 40 8537 1298  
Fax +49 (0) 40 8537 1331  
Email germany@amot.com

AMOT Russia  
#34 Shabolovka Street  
Building 2  
Moscow 115419  
Russia

Tel: +7 495 617 12 93  
Fax: +7 495 913 97 65