

Metal Particle Detector

Model MPD
Stainless steel

Overview

The Metal Particle Detector switch from AMOT can detect and alert equipment operations of the presence of metal particles in non-conductive fluid lubrication systems (lube oil, transmission fluid etc).



MPD - Metal Particle Detector

Typical applications

Developed for use in manual and automatic control systems:

- Reciprocating equipment
 - gas engines
 - diesel engines
 - compressors
- Rotating equipment
 - gas turbines
 - steam turbines
 - transmissions and gear boxes
 - pumps
 - compressors

Key features and benefits

- Unique grid sensing technology
 - detects metal particles and metal chips
 - detects all conductive metal particles (including non magnetic metal particles)
- Provides early warning of impending failure
 - reduced operating costs
 - corrective maintenance can be scheduled to minimize costly downtime
 - prevents unnecessary repairs and replacement of expensive parts

Approvals

UL Class Division 1, Groups A, B, C & 

amot

www.amot.com

Metal Particle Detector - MPD

Operation

Figure 1 - MPD Installation diagram

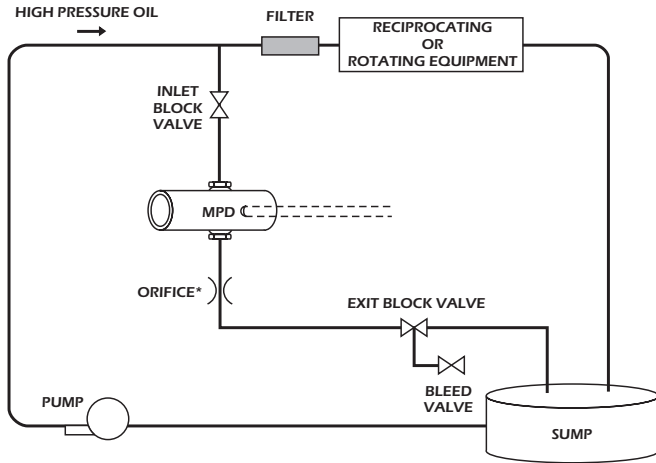

Operation is simple and straight forward. Process fluid, such as lube oil or transmission fluid, enters at the top of the MPD's body. Fluid then travels through a perforated board containing a plated electrical grid on the board's top and bottom sides. Fluid exits through the bottom of the MPD body (refer to Figure 1).

Figure 2 - MPD Switch diagram

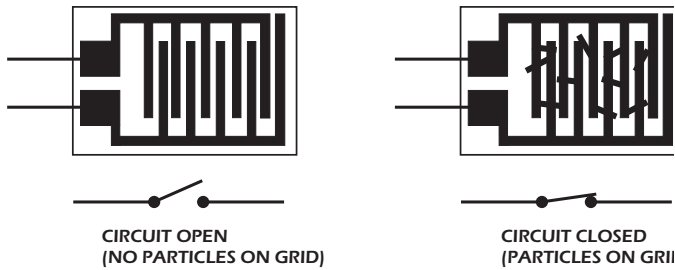

Activation of the MPD switch occurs when metal particles bridge the gaps on its electrical grid and complete a normally open (N.O.) electrical circuit to drive an alarm or shutdown relay (refer to Figure 2).

Metal particles gather on the MPD's grid to complete an electrical circuit. Refer to right diagram.

Metal Particle Detector - MPD

Design considerations

The following considerations should be noted when installing the metal particle detector:

- **Locating where the MPD will be mounted**

The MPD must be located in a side stream of the lube oil/fluid system, after the pump but before the filter.

- **Mounting the MPD**

Mount the MPD with the grid in horizontal position.

- **Hazardous area requirements**

Hazardous area rating requires that a safety barrier is installed. The following must also be complied with:

- **Piping the process fluid to the MPD**

Do not permit debris to enter the MPD while piping (this may close the MPD grid circuit).

- **Making MPD electrical connections**

All wiring to and from the MPD should be done in accordance with the applicable electrical code.

Figure 3 - MPD Hazardous area diagram

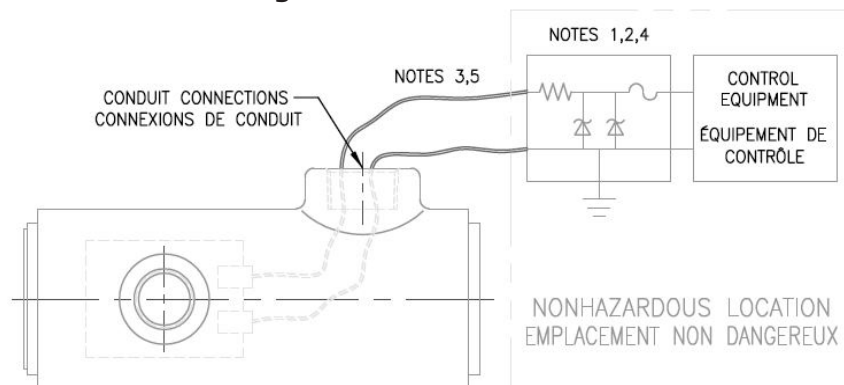

1. Selected safety barriers shall be listed or approved with intrinsically safe circuits for class I, groups A, B, C, & D.

2. Output current of the barrier must be limited by a resistor such that the output voltage-current plot is a straight line drawn between open circuit voltage and short circuit current.

3. Intrinsically safe wiring must be installed in accordance with the national electrical code, ANSI/NFPA 70, Article 50 and the Canadian electrical code where applicable.

4. Safety barrier must meet the following parameters:

$$\begin{aligned} V_{oc} &\leq V_{max}=28 \\ I_{sc} &\leq I_{max}=100mA \\ C_a &\geq C_i+C_{cable} \\ L_a &\geq L_i+L_{cable} \end{aligned}$$

5. If the electrical parameters of the cable are unknown, the following values must be used to calculate: C_{cable} and L_{cable}
Capacitance=60pF/ft Inductance=0.2μH/ft

Example: 1000ft of cable would equal:

$$C_{cable} = 1000ft \times 60pF/ft = 0.6\mu F$$

$$L_{cable} = 1000ft \times 0.2\mu H/ft = 0.2\mu H$$

6. The metal particle detector entity parameters for class I, groups A,B,C & D hazardous locations are:

$$V_{max} = 28V \quad C_i=0$$

$$I_{max}=100mA \quad L_i=0$$

Metal Particle Detector - MPD

Specification

Body & end caps:	316 stainless steel	
Seals:	Viton (Buna N optional)	
Electrical connections:	Plated tin	
Oil port connections:	1/2" NPT	
Electrical connection:	3/4" NPT	
Grid electrical ratings:	3.5 va. 24 volts (AC or DC) Maximum recommended for operator safety. Intrinsically safe power supplies may also be used.	
Temperature rating:	-23 to 177°C (Viton)	(-10 to 350°F) (Viton)
	-48 to 121°C (Buna)	(-54 to 250°F) (Buna N)
Max. working pressure:	13.8 bar	(200 psi)
Recommended wire gauge:	1.5mm ²	(16 gauge)
Lead wire gauge:	1.5mm ²	(16 gauge)
Flow coefficient:	Kv = 3.78	(Cv = 4.39)
Grid specification:	Hole size	0.8mm (1/32")
	Grid space distance	1.6mm (1/16")
Approvals:	UL Class, Division 1,	Groups A, B, C & D

How to order

Use the tables below to select the unique specification of your MPD Metal Particle Detector or specify the following information:

Example	MPD2R	T	5	P	2	-AA	Code Description
Model and design level	MPD2R						Basic Stainless Steel Model
							Port Connection
Oil Port Connection		T					1/2" NPT
		W					1/2" SAE
		U					1/2" BSP (PL)
							Connection Tube
			5				3/4 NPT
							Electrical Connection Type
Electrical Connection Type				P			Terminal plug
				T			Terminal block
				W			Wire leads 18"
				D			DIN Connector C/W Earth Wire
							Seal Material
Seal material					1		Buna N (Nitrile)
					2		Viton
							Special requirements
Special requirements						-AA	Standard
						**	Special requirements

Metal Particle Detector - MPD

Dimensions

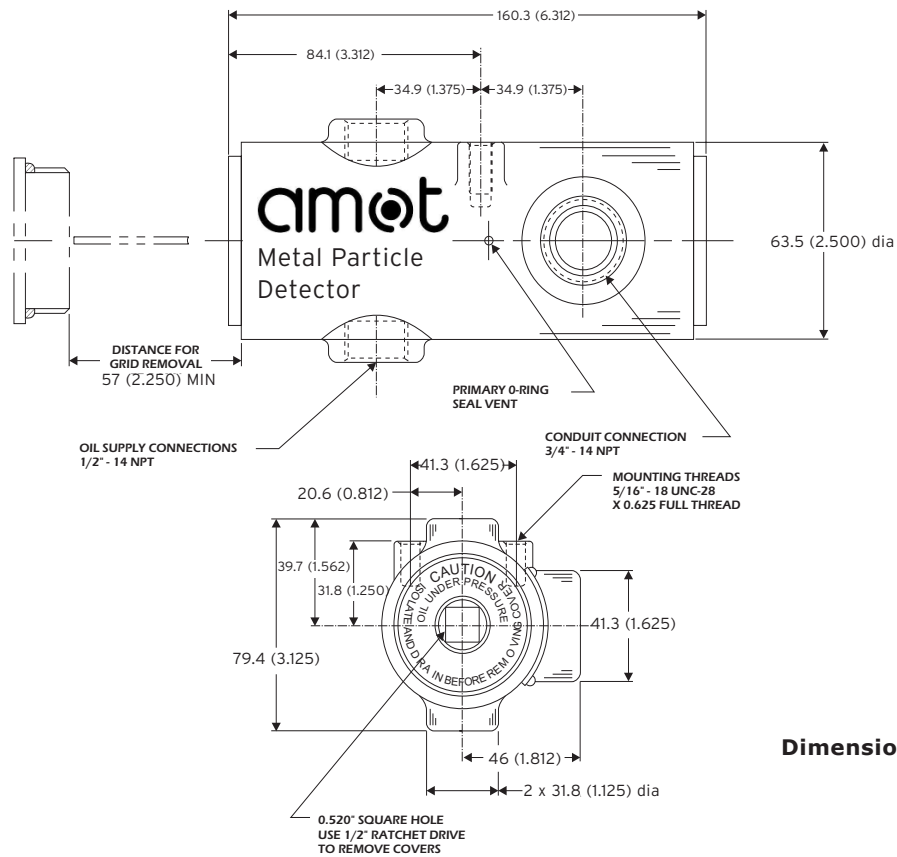

Service kits

Recommended spares/service parts

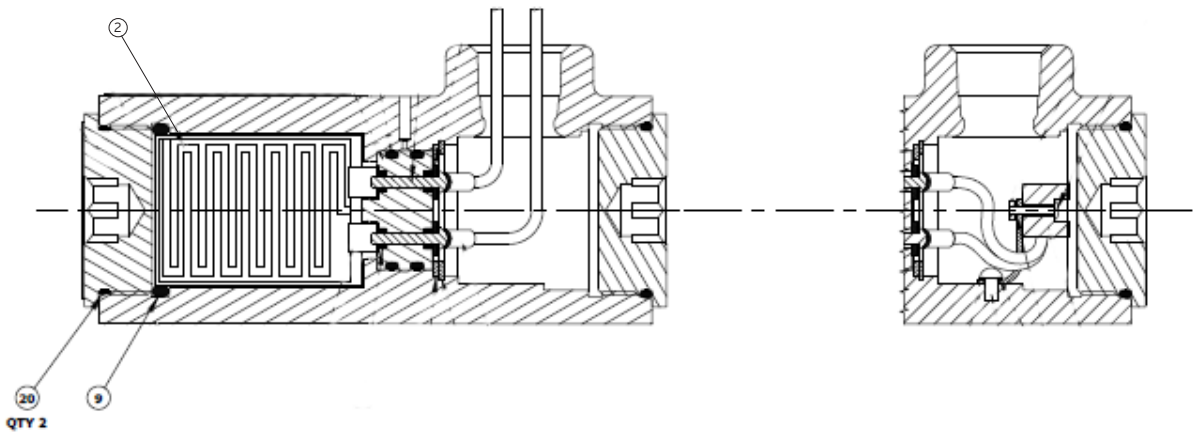

Stainless steel version - Kit Part no: 10829X001

Ref. No.	Qty.	Description
2	1	Grid
20	2	End Cap O-Ring (Viton)
9	1	Grid O-Ring Seal (Viton)

Europe, Middle East and Africa

AMOT
Western Way
Bury St Edmunds
Suffolk, IP33 3SZ
United Kingdom

Tel +44 (0) 1284 762222
Fax +44 (0) 1284 760256
Email info@amot.com

AMOT Controls GmbH
Rondenbarg 25
22525 Hamburg
Germany

Tel +49 (0) 40 8537 1298
Fax +49 (0) 40 8537 1331
Email germany@amot.com

Asia and Australasia

AMOT Shanghai
Bd. 7A, No. 568, Longpan Rd.
Malu Jiading
Shanghai 201801
China

Tel +86 (0) 21 6279 7700
Fax +86 (0) 21 5237 8560
Email shanghai@amot.com

Americas

AMOT USA
8824 Fallbrook Dr
Houston, TX 77064
USA

Tel +1 (281) 940 1800
Fax +1 (713) 559 9419
Email general: sales@amotusa.com
orders: orders@amotusa.com
customer service: cs@amotusa.com