

Gas Turbine Fuel Control Valve

Model 8402

Overview

The 8402G Fuel Valve System is a balanced rotary valve with an electric stepper-motor actuator. This high performance gas turbine fuel control valve with fast operation speed and large turn down ratio is designed for reliable and efficient control of any gas turbine.

Typical applications

- Custom designed specifically for gas fuel control (metering) for industrial or aero-derivative gas turbines
- Combined with AMOT's 4420 fuel shutoff valve, the 8402 can provide the complete gas turbine fuel control solution

Key benefits

- Precise turbine control - allows a single valve to be used where two valves were previously required.
- Full stroke operating speed of 250ms
- Digital optical encoder provides absolute repeatability of +/-0.05% of stroke
- Carbon steel or stainless steel construction - durable for long life
- All electric - eliminates need for a hydraulic actuation system



**Model 8402
Gas Turbine Fuel
Control Valve**

Operation

To meet the demands of virtually any industrial or aero-derivative gas turbine, the 8402 is equipped with an electric stepper-motor actuator, which can fully stroke the valve in only 250ms. The valve itself has a 500:1 turn down ratio which, in many applications, allows a single 8402 valve to provide precise fuel delivery to the turbine from light off to maximum power. This combination of features enables the value to enhance the performance of any gas turbine or turbomachinery train.

A key element in the performance of any fuel valve is the type and reliability of the position measurement device. Accuracy in position measurement is what allows the valve to make

the turbine operating in its maximum efficiency range while maintaining the safety of the machine and the entire turbomachinery train.

This system provides a position accuracy of 0.036° with respect to set point. A 4-20mA position signal feedback is provided. The acceleration/deceleration profiles of the stepper-motor are optimized for speed and torque by the control logic.

Electronic control system

The 8402 is controlled by a high-speed micro-processor in a separate enclosure. The controller receives a 4-20mA set point signal and converts this into a 12bit digital value to drive the stepper-motor/digital encoder loop.

The stepper-motor driver is capable of 1667 discrete steps across the 60° of full stroke actuation. Position feed back is provided by a 12bit absolute digital encoder providing a resolution of 0.022° of position per bit. The encoder signal/value position is compared to the set point value to verify position accuracy. An error signal is calculated by comparing the desired position (set point) with the valve position and is corrected by a precise digital signal to the stepper driver.

This system provides a position accuracy of 0.036° with respect to set point. A 4-20mA position signal feedback is provided. The acceleration/deceleration profiles of the stepper-motor are optimized for speed a torque by the control logic.

The controller is user/configurable for: loss of signal action, loss of feedback action, set point/valve position, calibration, valve action and hysteresis. An E²PROM is provided for storage of the configured parameters.

Gas Turbine Fuel Control Valve - Model 8402

Specification

Valve

Flow Coefficient	Kv	10.4, 21.6, 26, 52, 77.9
	Cv	12, 25, 30, 60, 90
Turn down	500:1	
Connections	2" (50.8mm) ANSI Class 600 RF flange	3" (76.2mm) ANSI Class 600 RF flange
Body material	Carbon steel	Stainless steel
Trim material	Stainless steel	
Seal material	Viton/PTFE	
Flow direction	Over trim	
Operating range	-22°C to 90°C	-8°F to 194°F

Actuator

Drive	Stepper-motor
Position measurement	Digital optical encoder
Enclosure	Class 1, Division 1, Groups C & D
NEMA rating	7 & 9
Operating speed-full stroke	250 milliseconds
Mounting orientation	Any

Actuator controls

Input signal	4-20mA	
Electronics	Digital	
Voltage	24 volts dc @ 8 amps	
Action	Reverse or direct (configurable)	
Failure mode	Freeze or close (configurable)	
Position repeatability	+/-0.05%	
Valve position transmitter signal	4-20mA	
Zero and span adjustments	Configurable	
Operating environment	0°C to 50°C	32°F to 122°F
Input impedance	250 Ohms	

Accreditations

The actuator enclosure is designed for use in hazardous environments and has been certified by CSA (Class I, Division 1, groups C & D, explosion proof).

Gas Turbine Fuel Control Valve - Model 8402

Dimensions

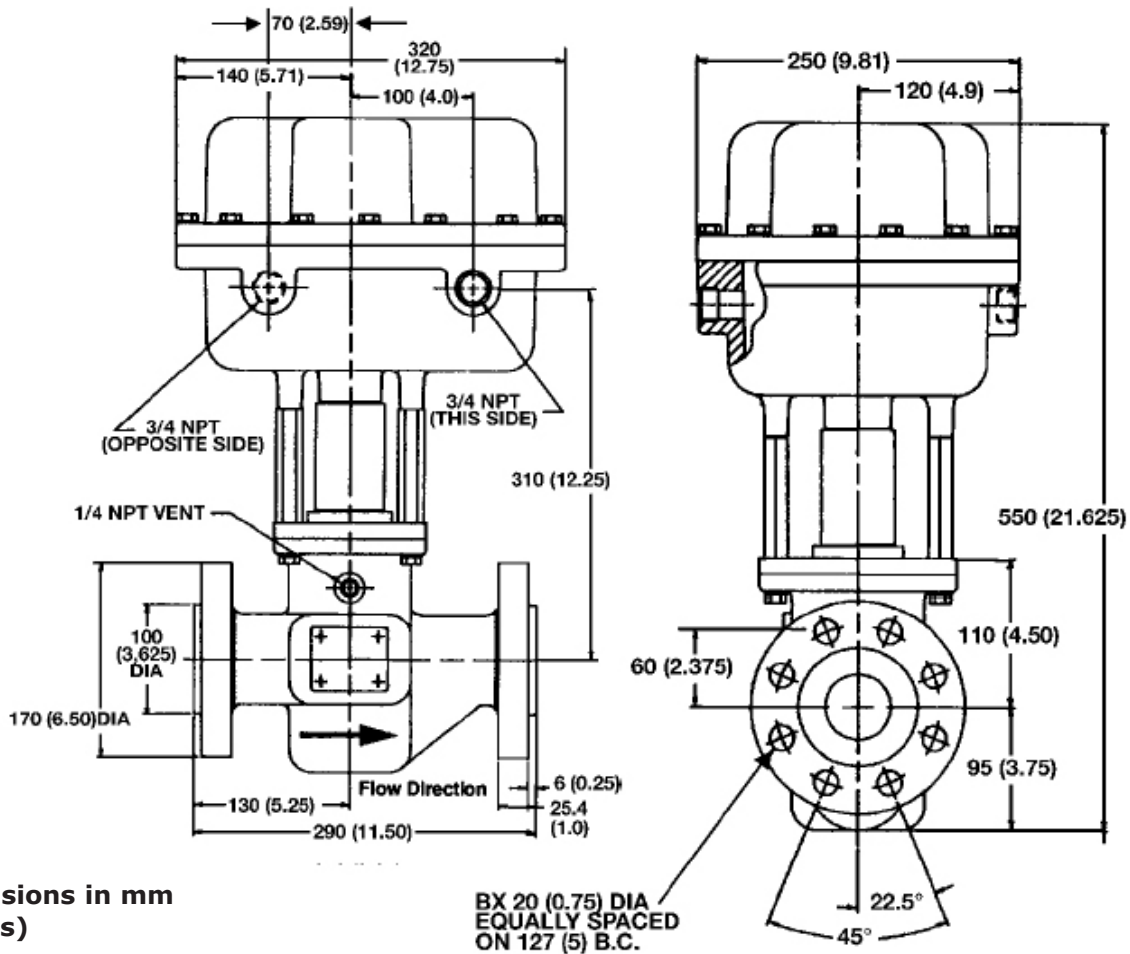

Dimensions in mm
(inches)

Electronic Control Enclosure

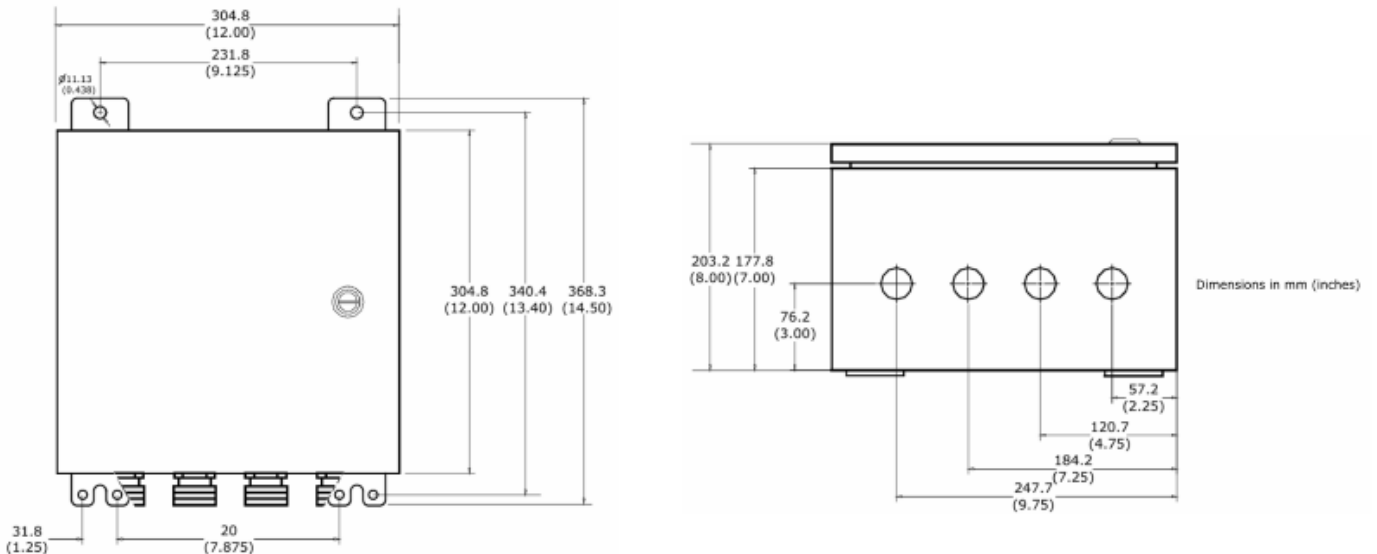

Gas Turbine Fuel Control Valve - Model 8402

Specification check list

Use the tables below to select the unique specification of your 8402 valve.

Example	8402G	1	4	A	2	E	AA	Comments
								Basic model
Basic model	8402G							Gas turbine fuel control valve
								Power supply
Power supply		1						24VDC
								Controller enclosure
Controller enclosure			4					Standard
								System style
System style				A				Standard
								Actuator enclosure
Actuator enclosure					1			NEMA 4, 7; non-approved
					2			NEMA 4, 7; CSA listed
								Valve connection /flow
Valve connection/flow						A		2", 600#, steel Cv = 12, Kv = 10.4
						B		2", 600#, steel, Cv = 25, Kv = 21.6
						C		2", 600#, steel, Cv = 30, Kv = 26
						D		3", 600#, steel, Cv = 60, Kv = 52
						E		3", 600#, steel, Cv = 90, Kv = 77.9
						L		2", 600#, stainless steel, Cv = 12, Kv = 10.4
						M		2", 600#, stainless steel, Cv = 25, Kv = 21.6
						N		2", 600#, stainless steel, Cv = 30, Kv = 26
						P		3", 600#, stainless steel, Cv = 60, Kv = 52
						R		3", 600#, stainless steel, Cv = 90, Kv = 77.9
								Special requirements
Special requirements							AA	

Americas

AMOT USA
8824 Fallbrook Dr
Houston, TX 77064
USA

Tel +1 (281) 940 1800
Fax +1 (713) 559 9419
Email customer.service@amot.com

Asia Pacific

AMOT Shanghai
Bd. 7A, No. 568, Longpan Rd., Malu Jiading
Shanghai 201801
China

Tel: +86 21 5910 4052
Fax: +86 21 5237 8560
Email: shanghai@amot.com

Europe, Middle East and Africa

AMOT
Western Way
Bury St Edmunds
Suffolk, IP33 3SZ
England

Tel +44 (0) 1284 715739
Fax +44 (0) 1284 760256
Email info@amot.com

AMOT Controls GmbH
Rondenbarg 25
22525 Hamburg
Germany

Tel +49 (0) 40 8537 1298
Fax +49 (0) 40 8537 1331
Email germany@amot.com